

GOOD PRACTICES FOR BATCH CHARGING INTO THE PROCESS - GLASS

This activity relates to the charging of the humid batch by special charging machines from the furnace hopper into the melting furnace, which due to its operating conditions (high temperatures combined with positive pressure) generates a certain amount of dust.

ACCESS

Restrict access to the work area to authorised personnel only.

DESIGN AND EQUIPMENT

- Ensure that charging equipment is fit for purpose and well maintained.
- Adjust the sand seal system in accordance to supplier recommendations.
- Enclose the charging area as far as technically feasible.
- Assure the batch is charged at the appropriate humidity factor into the furnace.
- Furnace hoppers for the wet batch material should have an opening as small as practicable.
- Furnace hopper to be equipped with high level detection linked to alarming system to avoid overfilling.
- Ensure proper ventilation in the charging area.

MAINTENANCE

- Ensure that the equipment is maintained as advised by the supplier in efficient working conditions.
- Check sand seal system on a daily base and adjust if necessary in accordance to supplier recommendations.

EXAMINATION AND TESTING

- Visually check the equipment for signs of damage at least once per week or, if it is in constant use, check it more frequently. If used infrequently, then check it before each use.
- Keep records of inspections for a suitable period of time which complies with national laws (minimum five years).
- Put in place measures to control the risk of bacterial growth within water sources used across site, focusing most on systems where water droplets will be generated.



CLEANING AND HOUSEKEEPING

- In order to prevent dust accumulation, clean the workplace on a regular basis.
- Deal immediately with spills. When dealing with bulk spillages of fine, dry, dusty materials, ensure that cleaning work is undertaken following a written safe working procedure and using the information in this sheet.
- Use vacuum or wet cleaning methods.
- **DO NOT clean up with a dry brush or using compressed air.**

TRAINING

- Give your employees information on the health effects associated with respirable crystalline silica dust.
- Provide employees with training on: dust exposure prevention; checking controls are working and using them; when and how to use any respiratory protective equipment provided and what to do if something goes wrong. Refer to task guidance sheet **2.3.4** and part 1 of the Good Practice Guide.

SUPERVISION

- Have a system to check that control measures are in place and that they are being followed. Refer to task guidance sheet **2.3.3**.
- Employers should make sure that employees have all the means to perform the checklist given below.



PERSONAL PROTECTIVE EQUIPMENT

- Refer to task guidance sheet **2.1.15** dedicated to Personal Protective Equipment.
- If necessary, respiratory protective equipment should be provided and worn.
- Provide storage facilities to keep personal protective equipment clean when not in use.
- Replace respiratory protective equipment at intervals recommended by its suppliers.
- Risk assessment could be carried out to determine whether existing controls are appropriate.

EMPLOYEE CHECKLIST

- | | | | |
|--|--|--|---|
| <input type="checkbox"/> Verify proper function of sand seal. If you notice any anomaly, inform your supervisor. | <input type="checkbox"/> Immediately cleaning up bulk spillages of fine, dry dusty materials by using vacuum or wet cleaning methods. Ensure that you work in accordance with your Company's written safe working instruction. | <input type="checkbox"/> Use, maintain and store any person protective equipment provided in accordance with instructions. | <input type="checkbox"/> Check and implement the measures of controlling the risk of bacterial growth within water sources used across site, focusing most on systems where water droplets will be generated. |
|--|--|--|---|

This guidance sheet is aimed at employers to help them comply with the requirements of workplace health and safety legislation, by controlling exposure to respirable crystalline silica. Specifically, this sheet provides advice on the charging of the humid batch by special charging machines from the furnace hopper into the melting furnace.

Following the key points of this task guidance sheet will help reduce exposure.

Depending on the specific circumstances of each case, it may not be necessary to

apply all of the control measures identified in this sheet in order to minimise exposure to respirable crystalline silica. i.e. to apply appropriate protection and prevention measures. This document should also be made available to persons who may be exposed to respirable crystalline silica in the workplace, in order that they may make the best use of the control measures which are implemented.

This sheet forms part of the Good Practices Guide on silica dust prevention, which is aimed specifically at the control of personal exposure to respirable crystalline silica dust in the workplace.

GOOD PRACTICES FOR BULK ROAD TANKER UNLOADING (BLOWING OFF)

This activity covers the discharge of silica sand and flour products from a road tanker into a storage silo, particularly dry materials.

ACCESS

Restrict access to the work area to authorised personnel only.

DESIGN AND EQUIPMENT

Road Tanker

- Limit the discharge rate to the design capacity of the receiving silo and dust extraction unit. Offloading pressures should be agreed with the silo operator.
- Tanker offloading pipes, connectors and seals must be designed to withstand the high air pressures and abrasion associated with blowing operations.
- Note that there will be a surge of air pressure as the last sand/flour is blown into a silo. Hence the need for constant supervision of offloading operations.

Customer silo

- Storage silos should be purchased only from reputable suppliers.
- Appropriate engineering design methods should be employed to ensure adequate structural strength.
- Engineering controls must be employed to prevent over-pressurisation of the silo while it is being filled. Ensure that the silos are equipped with pressure relief devices and high level alarms. They must also have dust extraction systems to remove and clean the displaced air.
- Silo dust extraction units must be fitted with filters that are appropriate to the particle size range of the product.
- Offloading pressures should be agreed with the tanker operator.
- Note that flour products have varying bulk density. Put in place procedures to ensure that silos are not overfilled.
- Silos should be equipped with a dust extraction system to prevent the emission of dust from the silo during tanker offloading.

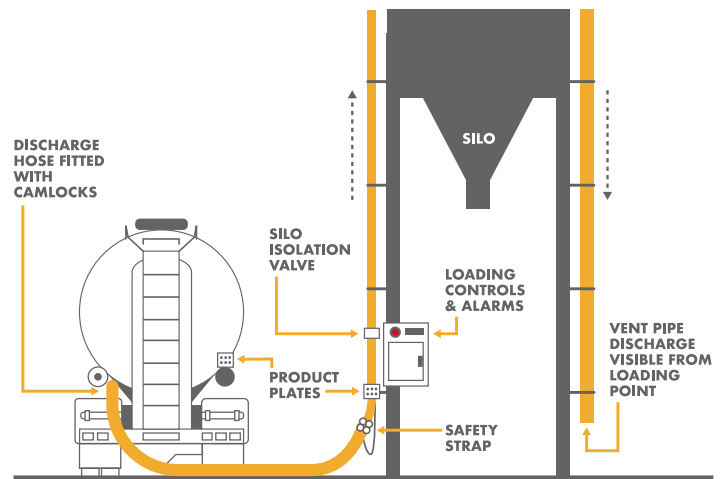

- Pipework and ductwork should be designed to minimise shock losses (caused by bends, constrictions etc.); to minimise dead spots where material may accumulate and to facilitate easy clearing of blockages.
- Silo connection points should be located as close as possible to the delivery tanker parking area. This will eliminate the need for long lengths of flexible hose.
- Safe means of access should be provided to those parts of the silo requiring inspection and maintenance.

MAINTENANCE

- Maintain pipes/hoses, connectors and seals in good condition to reduce the likelihood of dust escaping during blowing operations.
- Dust extraction systems on silos must be maintained in accordance with manufacturers' instructions.

EXAMINATION AND TESTING

- A competent person should test the performance of dust extraction systems at least annually.
- Tanker drivers should check the condition of pipes/hoses and seals daily and obtain replacements as necessary.
- Any faults with the pipes/hoses/connectors and silo dust extraction systems must be reported as soon as possible so that remedial action can be taken.
- Put in place measures of controlling the risk of bacterial growth within water sources used across site, focusing most on systems where water droplets will be generated.

CLEANING AND HOUSEKEEPING

- The tanker offloading area should be kept clean and tidy.
- Clean your workplace on a regular basis.
- Deal with spills immediately.
- **DO NOT clean up with a dry brush or using compressed air.**
- Use vacuum or wet cleaning methods.

TRAINING

- Give your employees information on the health effects associated with respirable crystalline silica dust.

- Provide employees with training on: dust exposure prevention; checking controls are working and using them; when and how to use any respiratory protective equipment provided and what to do if something goes wrong. Refer to task guidance sheet **2.3.4** and part 1 of the Good Practice Guide.

SUPERVISION

- Ensure procedures are in place to prevent overfilling of silos.
- Have a system to check that dust control measures are in place and that they are being followed. Refer to task guidance sheet **2.3.3**.
- Employers should make sure that employees have all the means to perform the checklist given below.

PERSONAL PROTECTIVE EQUIPMENT

- Refer to task guidance sheet **2.1.15** dedicated to Personal Protective Equipment.
- Risk assessment must be carried out to check the effectiveness of control measures.
- Respiratory protective equipment (with the appropriate protection factor) may need to be worn when disconnecting the offloading pipe at the back of the tanker, when remedying any escape of dust or in the event control measures fail.
- Provide storage facilities to keep personal protective equipment clean when not in use. Replace this equipment at intervals recommended by suppliers.

EMPLOYEE CHECKLIST

- | | | | |
|--|--|--|---|
| <input type="checkbox"/> Tanker drivers must supervise their offloading operations at all times. | <input type="checkbox"/> Look for signs of damage, wear or poor operation of any equipment used. If you find any problems, tell your supervisor. | <input type="checkbox"/> Clean up spillages of sand and flour immediately, using wet cleaning methods. | <input type="checkbox"/> Use, maintain and store any respiratory protective equipment provided in accordance with instructions. |
| <input type="checkbox"/> Agree offloading pressures with the customer. | <input type="checkbox"/> If you think there is a problem with your dust control equipment, ensure additional control measures are taken to reduce exposure to respirable crystalline silica dust while the problem persists. | <input type="checkbox"/> Wear a dust mask when it is necessary to enter dusty areas in order to rectify any escape of dust, or in the event other control measures fail. | <input type="checkbox"/> Check and implement the measures of controlling the risk of bacterial growth within water sources used across site, focusing most on systems where water droplets will be generated. |
| <input type="checkbox"/> Check the condition of pipes, hoses and connectors daily. | | | |

This guidance sheet is aimed at employers to help them comply with the requirements of workplace health and safety legislation, by controlling exposure to respirable crystalline silica. Specifically, this sheet provides advice on how to minimise the release of airborne dust when blowing off a road tanker of silica sand or flour.

Following the key points of this task guidance sheet will help reduce exposure.

Depending on the specific circumstances of each case, it may not be necessary to apply all of the control measures identified in this sheet in order to minimise exposure

to respirable crystalline silica. i.e. to apply appropriate protection and prevention measures. This document should also be made available to persons who may be exposed to respirable crystalline silica in the workplace, in order that they may make the best use of the control measures which are implemented.

This sheet forms part of the Good Practices Guide on silica dust prevention, which is aimed specifically at the control of personal exposure to respirable crystalline silica dust in the workplace.

GOOD PRACTICES FOR BULK UNLOADING

This activity covers bulk unloading operations for road (except road tankers), rail and water transport of crystalline silica containing materials, particularly dry materials. Sheet **2.2.4a** offers advice on unloading of road tankers.

ACCESS

Restrict access to the work area to authorised personnel only.

DESIGN AND EQUIPMENT

- Ensure that all unloading equipment is fit for purpose and well maintained.
- When discharging dry products, install dust extraction systems in areas where dust may be emitted into the workplace air.
- Consider isolating the discharge area and keeping it under negative pressure. Alternatively, provide control rooms which are sealed and kept under positive pressure.
- The truck driver should remain in the cab of the truck during unloading with the doors and windows closed. Where possible, a HEPA filter should be incorporated in the cab's HVAC system.
- Design the size and shape of receiving hoppers so that they are appropriate to the capacity of the road haulage vehicles, rail wagons, grabs etc feeding them.
- Prepare offloading procedures. Ensure that hoppers and discharge areas are clearly labelled with their contents.
- **DO NOT discharge flour products in the open air; enclosed systems must be used.**
- See task guidance sheet **2.2.4a** entitled "Bulk Road Tanker Unloading" for advice on blowing off dry products from road tankers.

MAINTENANCE

- Ensure equipment used in the task is maintained as advised by the supplier/installer in efficient working order and in good repair.
- Replace consumables (filters etc.) in accordance with the manufacturer's recommendations.



EXAMINATION AND TESTING

- Visually check the cleaning equipment for signs of damage at least once per week or, if it is in constant use, check it more frequently. If used infrequently, then check it before each use.
- Obtain information on the design performance of dust extraction equipment from the supplier. Keep this information to compare it with future test results.
- Keep records of inspections for a suitable period of time which complies with national laws (minimum five years).
- Put in place measures to control the risk of bacterial growth within water sources used across site, focusing most on systems where water droplets will be generated.

CLEANING AND HOUSEKEEPING

- Clean your workplace on a regular basis.
- Deal with spills immediately.
- **DO NOT clean up with a dry brush or using compressed air.**
- Use vacuum or wet cleaning methods.

TRAINING

- Give your employees information on the health effects associated with respirable crystalline silica dust.
- Provide employees with training on: dust exposure prevention; checking controls are working and using them; when and how

to use any respiratory protective equipment provided and what to do if something goes wrong. Refer to task guidance sheet **2.3.4** and part 1 of the Good Practice Guide.

- Ensure that delivery drivers are provided with copies of offloading procedures and training on these as necessary.

SUPERVISION

- Have a system to check that control measures are in place and that they are being followed. Refer to task guidance sheet **2.3.3**.
- Employers should make sure that employees have all the means to perform the checklist given below.

PERSONAL PROTECTIVE EQUIPMENT

- Refer to task guidance sheet **2.1.15** dedicated to Personal Protective Equipment.
- Risk assessment must be carried out to determine whether existing controls are adequate. If necessary, respiratory protective equipment (with the appropriate protection factor) should be provided and worn.
- Indicate the need for respiratory protective equipment to be worn using appropriate pictogram signs.
- Provide storage facilities to keep personal protective equipment clean when not in use.
- Replace respiratory protective equipment at intervals recommended by its suppliers.

EMPLOYEE CHECKLIST

- | | | | |
|--|---|---|---|
| <input type="checkbox"/> Make sure the unloading equipment is working properly. | <input type="checkbox"/> Look for signs of damage, wear or poor operation of any equipment used. If you find any problems, tell your supervisor. | <input type="checkbox"/> Clear up spills straight away. Use vacuum or wet cleaning methods. | <input type="checkbox"/> Check and implement the measures to control the risk of bacterial growth within water sources used across site, focusing most on systems where water droplets will be generated. |
| <input type="checkbox"/> Make sure the dust extraction system is switched on and is working. | <input type="checkbox"/> If you think there is a problem with your dust control equipment, ensure additional control measures are taken to reduce exposure to | <input type="checkbox"/> Use, maintain and store any respiratory protective equipment provided in accordance with instructions. | |
| <input type="checkbox"/> Wear respiratory protective equipment (e.g. a dust mask) in areas where this has been deemed necessary. | | | |

This guidance sheet is aimed at employers to help them comply with the requirements of workplace health and safety legislation, by controlling exposure to respirable crystalline silica. Specifically, this sheet provides good practice advice on dust control during bulk unloading operations.

Following the key points of this task guidance sheet will help reduce exposure.

Depending on the specific circumstances of each case, it may not be necessary to apply all of the control measures identified in this sheet in order to minimise exposure

to respirable crystalline silica. i.e. to apply appropriate protection and prevention measures. This document should also be made available to persons who may be exposed to respirable crystalline silica in the workplace, in order that they may make the best use of the control measures which are implemented.

This sheet forms part of the Good Practices Guide on silica dust prevention, which is aimed specifically at the control of personal exposure to respirable crystalline silica dust in the workplace.

GOOD PRACTICES FOR DRYING MINERALS/RAW MATERIALS

This activity covers the operation for drying and cooling of products containing crystalline silica.

ACCESS

Restrict access to the work area to authorised personnel only.

DESIGN AND EQUIPMENT

- Ensure that all drying/cooling equipment is fit for purpose and that it is well maintained.
- The plant should be enclosed as far as possible. Fluid bed dryers are generally more enclosed than rotary dryers.
- Outdoor installation of mineral dryers and coolers will help to reduce personal exposure to respirable crystalline silica dust, by taking advantage of natural ventilation. However, dryers and coolers that are installed outdoors will need to be designed for increased weather resistance.
- In situations where dryers and coolers are installed indoors, forced ventilation may be required in the building in order to ensure adequate dilution and removal of dusty air.
- Install a dust extraction system to serve all points from which dust may escape from the drying/cooling equipment and to maintain the system under negative pressure. This should be connected to a suitable dust extraction unit (e.g. a bag filter, cyclone or wet scrubber).
- Fine dust collected by the dust extraction unit can be returned to the dried product if additional precautions (e.g. closed circuit) are taken to protect those who may be exposed to this dust downstream, for example during bulk loading operations.
- Control cabins should have their own clean air supply. Where necessary, they should be equipped with forced air filtration and maintained under positive pressure. Dryer/cooler controls should be via telemetry in order to reduce the need for operators to visit dusty/noisy areas.
- Mineral dryers and coolers are subject to particulate emission limits and must be designed to satisfy local rules.



MAINTENANCE

- Ensure equipment used in the task is maintained as advised by the supplier/installer in efficient working order and in good repair.
- Replace consumables (filters etc.) in accordance with the manufacturer's recommendations.

GUIDANCE FOR EMPLOYERS ON CONTROLLING EXPOSURE TO RCS IN THE WORKPLACE

EXAMINATION AND TESTING

- Visually check the equipment at least once per week for signs of damage or, if it is in constant use, check it more frequently. If used infrequently, then check it before each use.
- Obtain information on the design performance of the dust suppression and/or extraction equipment from the supplier. Keep this information to compare with future test results.
- Have the equipment examined and tested against its performance standard, at least once each year.
- Keep records of inspections for a suitable period of time which complies with national laws (minimum five years).
- Put in place measures to control the risk of bacterial growth within water sources used across site, focusing most on systems where water droplets will be generated.

CLEANING AND HOUSEKEEPING

- Clean your workplace on a regular basis.
- **DO NOT clean up with a dry brush or using compressed air.**
- Use vacuum or wet cleaning methods.

TRAINING

- Give your employees information on the health effects associated with respirable crystalline silica dust.

- Provide employees with training on: dust exposure prevention; checking controls are working and using them; when and how to use any respiratory protective equipment provided and what to do if something goes wrong. Refer to task guidance sheet **2.3.4** and part 1 of the Good Practice Guide.

SUPERVISION

- Have a system to check that control measures are in place and that they are being followed. Refer to task guidance sheet **2.3.3**.
- Employers should make sure that employees have all the means to perform the checklist given below.

PERSONAL PROTECTIVE EQUIPMENT

- Refer to task guidance sheet **2.1.15** dedicated to Personal Protective Equipment.
- Risk assessment must be carried out to determine whether existing controls are adequate. If necessary, respiratory protective equipment (with the appropriate protection factor) should be provided and worn.
- Provide storage facilities to keep personal protective equipment clean when not in use.
- Replace respiratory protective equipment at intervals recommended by its suppliers.

EMPLOYEE CHECKLIST

- | | | | |
|--|---|---|---|
| <input type="checkbox"/> Make sure that the dust extraction system is switched on and is working correctly. | <input type="checkbox"/> If you think there is a problem with your dust control equipment, ensure additional control measures are taken to reduce exposure to respirable crystalline silica while the problem persists. | <input type="checkbox"/> Clean up control rooms using vacuum or wet cleaning methods. | <input type="checkbox"/> Check and implement the measures to control the risk of bacterial growth within water sources used across site, focusing most on systems where water droplets will be generated. |
| <input type="checkbox"/> Look for signs of damage, wear or poor operation of any equipment used. If you find any problems, tell your supervisor. | <input type="checkbox"/> Clear up spills straight away. Use vacuum or wet cleaning methods. | <input type="checkbox"/> Test if control rooms are under pressure, keep doors and windows shut. | |
| | | <input type="checkbox"/> Use, maintain and store any respiratory protective equipment provided in accordance with instructions. | |

This guidance sheet is aimed at employers to help them comply with the requirements of workplace health and safety legislation, by controlling exposure to respirable crystalline silica. Specifically, this sheet provides good practice advice on dust control for drying operations.

Following the key points of this task guidance sheet will help reduce exposure.

Depending on the specific circumstances of each case, it may not be necessary to apply all of the control measures identified in this sheet in order to minimise exposure

to respirable crystalline silica. i.e. to apply appropriate protection and prevention measures. This document should also be made available to persons who may be exposed to respirable crystalline silica in the workplace, in order that they may make the best use of the control measures which are implemented.

This sheet forms part of the Good Practices Guide on silica dust prevention, which is aimed specifically at the control of personal exposure to respirable crystalline silica dust in the workplace.

GOOD PRACTICES FOR GRINDING OF MINERALS/RAW MATERIALS

This sheet gives guidance on dry grinding operations for products containing crystalline silica.

ACCESS

Restrict access to the work area to authorised personnel only.

DESIGN AND EQUIPMENT

- Ensure the grinding installation is fit for purpose and that it is well maintained.
- Use wet milling processes wherever possible, rather than dry grinding operations. This will greatly reduce airborne dust generation.
- Enclose grinding installations as much as possible and install them in well-ventilated buildings.
- Where necessary to prevent the escape of dust, grinding installations should be connected to a suitable dust extraction system, which is capable of extracting enough air to keep the relevant parts of the installation under negative pressure.
- Make arrangements for the dust-free discharge of the product from the grinding mill to other process equipment. Transfer points and subsequent plant should also be connected to a dust extraction system where necessary to prevent the escape of dust.
- Note that some parts of the system will operate at pressures above atmospheric. Provide good seals between different parts of the installation.
- Ensure all equipment is easily accessible for maintenance work.
- Provide ducts with sufficient inclination to avoid settling of product.
- Ensure minimal internal wear of ducts by using ones of adequate diameter; by selecting wear resistant materials and by avoiding sharp bends. Alumina is a good material to use to line ducts that are subject to high wear.
- Control rooms should have their own clean air supply and they should be physically separated from dusty areas. Where necessary they should be fitted with forced air filtration and maintained under positive pressure to prevent the ingress of dusty air.
- Put in place control systems to avoid overloading the grinding mills.

- Where possible, provide automated sampling, particle size analysis, telemetry and CCTV systems to reduce the amount of time operators need to spend in dusty/noisy areas.

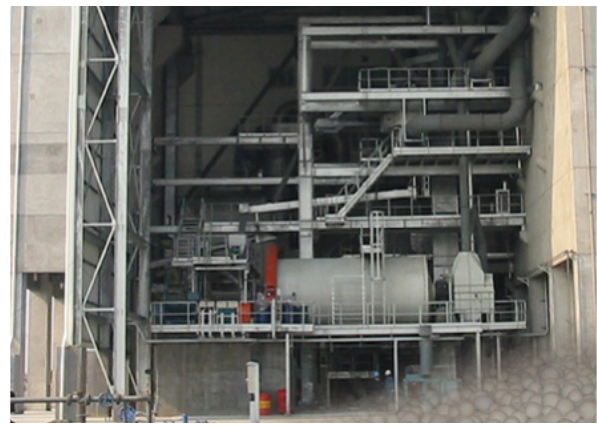

MAINTENANCE

- Ensure equipment used in the task is maintained as advised by the supplier/installer in efficient working order and in good repair.
- Replace consumables (filters etc.) in accordance with the manufacturer's recommendations.

EXAMINATION AND TESTING

- Visually check the equipment at least once per week for signs of damage or, if it is in constant use, check it more frequently. If used infrequently, then check it before each use.
- Obtain information on the design performance of the dust suppression and/or extraction equipment from the supplier. Keep this information to compare with future test results.
- Have the extraction equipment examined and tested against its performance standard at least once each year.
- Keep records of inspections for a suitable period of time which complies with national laws (minimum five years).
- Put in place measures to control the risk of bacterial growth within water sources used across site, focusing most on systems where water droplets will be generated.

CLEANING AND HOUSEKEEPING

- Clean your workplace on a regular basis.
- **DO NOT clean up with a dry brush or using compressed air.**
- Use vacuum or wet cleaning methods.
- Develop written safe working procedures for dealing with large spillages of dusty material.

TRAINING

- Give your employees information on the health effects associated with respirable crystalline silica dust.
- Provide employees with training on: dust exposure prevention; checking controls are working and using them; when and how to use any respiratory protective equipment provided and what to do if something goes wrong. Refer to task guidance sheet **2.3.4** and part 1 of the Good Practice Guide.

SUPERVISION

- Have a system to check that control measures are in place and that they are being followed. Refer to task guidance sheet **2.3.3**.
- Employers should make sure that employees have all the means to perform the checklist given below.

PERSONAL PROTECTIVE EQUIPMENT

- Refer to task guidance sheet **2.1.15** dedicated to Personal Protective Equipment.
- Risk assessment must be carried out to determine whether existing controls are adequate. If necessary, respiratory protective equipment (with the appropriate protection factor) should be provided and worn.
- Provide storage facilities to keep personal protective equipment clean when not in use.
- Replace respiratory protective equipment at intervals recommended by its suppliers.

EMPLOYEE CHECKLIST

- | | | | |
|--|---|---|---|
| <input type="checkbox"/> Make sure the grinding installation is working properly. | <input type="checkbox"/> Dust clouds may suggest a problem with the system. Investigate them immediately. | <input type="checkbox"/> Clear up spills straight away. Use vacuum or wet cleaning methods. Dispose of spills safely. | <input type="checkbox"/> Check and implement the measures to control the risk of bacterial growth within water sources used across site, focusing most on systems where water droplets will be generated. |
| <input type="checkbox"/> Make sure all dust extraction systems are switched on and working correctly before starting work. | <input type="checkbox"/> If you think there is a problem with the plant or with your dust control equipment, ensure additional control measures are taken to reduce exposure to respirable crystalline silica while the problem persists. | <input type="checkbox"/> Clean up control rooms using vacuum or wet cleaning techniques. | |
| <input type="checkbox"/> Look for signs of damage, wear or poor operation of any equipment used. If you find any problems, tell your supervisor. | | <input type="checkbox"/> Use, maintain and store any respiratory protective equipment provided in accordance with instructions. | |

This guidance sheet is aimed at employers to help them comply with the requirements of workplace health and safety legislation, by controlling exposure to respirable crystalline silica. Specifically, this sheet provides good practice advice on dust control for grinding operations.

Following the key points of this task guidance sheet will help reduce exposure.

Depending on the specific circumstances of each case, it may not be necessary to apply all of the control measures identified in this sheet in order to minimise exposure

to respirable crystalline silica. i.e. to apply appropriate protection and prevention measures. This document should also be made available to persons who may be exposed to respirable crystalline silica in the workplace, in order that they may make the best use of the control measures which are implemented.

This sheet forms part of the Good Practices Guide on silica dust prevention, which is aimed specifically at the control of personal exposure to respirable crystalline silica dust in the workplace.

GOOD PRACTICES FOR MIXING OF MATERIALS

This sheet provides guidance on the design and use of equipment used for the mixing of products containing crystalline silica, particularly dry products.

ACCESS

Restrict access to the work area to authorised personnel only.

DESIGN AND EQUIPMENT

- Ensure that mixers are fit for purpose and that they are well maintained.
- Enclose mixers as much as possible.
- Mixer lids and other access points should be sealed to prevent the escape of dust.
- All covers and access doors must be securely closed before starting the mixer.
- The mixer charging point should be enclosed and provided with local exhaust ventilation.
- Alternatively, local exhaust ventilation can be supplied at points inside the lid or rear of the mixer casing, so that there is a net influx of air through the charging point and into the mixer.
- All extraction systems should be designed so as not to draw excessive amounts of raw material from the mixer.
- When producing a dry mix, consider arrangements for dust-free discharge of mixed products. eg direct discharge to an enclosed conveyor system. Alternatively, provide local exhaust ventilation at the discharge point.
- Local exhaust ventilation systems must be connected to a suitable dust extraction unit.
- Where possible, mixer charging points should be located away from doors, windows and walkways to prevent draughts affecting the performance of local exhaust ventilation systems.
- Provide a clean air supply to the workroom to replace extracted air.

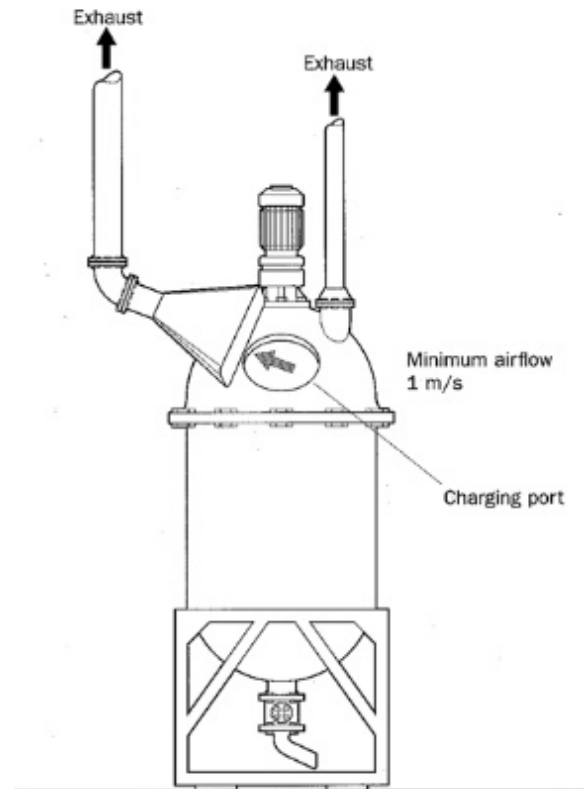

MAINTENANCE

- Ensure equipment used in the task is maintained as advised by the supplier/installer in efficient working order and in good repair.
- Replace consumables (filters etc.) in accordance with the manufacturer's recommendations.

EXAMINATION AND TESTING

- Visually check the cleaning equipment for signs of damage at least once per week or, if it is in constant use, check it more frequently. If used infrequently, then check it before each use.
- Obtain information on the design performance of dust suppression and/or extraction equipment from the supplier. Keep this information to compare with future test results.
- Keep records of inspections for a suitable period of time which complies with national laws (minimum five years).
- Put in place measures to control the risk of bacterial growth within water sources used across site, focusing most on systems where water droplets will be generated.

CLEANING AND HOUSEKEEPING

- Clean your workplace on a regular basis.
- Store containers in a safe place and dispose of empty containers safely.
- Put lids on containers immediately after use.
- Deal with spills immediately.
- **DO NOT clean up with a dry brush or using compressed air.**
- Use vacuum or wet cleaning methods.

TRAINING

- Give your employees information on the health effects associated with respirable crystalline silica dust.
- Provide employees with training on: dust exposure prevention; checking controls are working and using them; when and how to use any respiratory protective equipment provided and what to do if something goes wrong. Refer to task guidance sheet **2.3.4** and part 1 of the Good Practice Guide.

SUPERVISION

- Have a system to check that control measures are in place and that they are being followed. Refer to task guidance sheet **2.3.3**.
- Employers should make sure that employees have all the means to perform the checklist given below.

PERSONAL PROTECTIVE EQUIPMENT

- Refer to task guidance sheet **2.1.15** dedicated to Personal Protective Equipment.
- Risk assessment must be carried out to determine whether existing controls are adequate. If necessary, respiratory protective equipment (with the appropriate protection factor) should be provided and worn.
- Provide storage facilities to keep personal protective equipment clean when not in use.
- Replace respiratory protective equipment at intervals recommended by its suppliers.

EMPLOYEE CHECKLIST

- | | | | |
|--|--|---|---|
| <input type="checkbox"/> Make sure the work area is well ventilated and that any dust extraction system is switched on and is working correctly. | <input type="checkbox"/> Look for signs of damage, wear or poor operation of any equipment used. If you find any problems, tell your supervisor. | <input type="checkbox"/> Use, maintain and store any respiratory protective equipment provided in accordance with instructions. | <input type="checkbox"/> Check and implement the measures of controlling the risk of bacterial growth within water sources used across site, focusing most on systems where water droplets will be generated. |
| <input type="checkbox"/> Clear up spills straight away. Use vacuum or wet cleaning methods. Dispose of spills immediately. | <input type="checkbox"/> If you think there is a problem with your dust control equipment, ensure additional control measures are taken to reduce exposure to respirable crystalline silica dust while the problem persists. | | |

This guidance sheet is aimed at employers to help them comply with the requirements of workplace health and safety legislation, by controlling exposure to respirable crystalline silica. Specifically, this sheet provides advice on dust control when mixing materials containing crystalline silica dust.

Following the key points of this task guidance sheet will help reduce exposure.

Depending on the specific circumstances of each case, it may not be necessary to apply all of the control measures identified in this sheet in order to minimise exposure

to respirable crystalline silica. i.e. to apply appropriate protection and prevention measures. This document should also be made available to persons who may be exposed to respirable crystalline silica in the workplace, in order that they may make the best use of the control measures which are implemented.

This sheet forms part of the Good Practices Guide on silica dust prevention, which is aimed specifically at the control of personal exposure to respirable crystalline silica dust in the workplace.

GOOD PRACTICES FOR PERIODIC AND CONTINUOUS DRYING

This activity relates to the drying of shaped fine and coarse ceramics made of materials containing crystalline silica.

ACCESS

Restrict access to the work area to authorised personnel only.

DESIGN AND EQUIPMENT

- Good thermal insulation should be applied.
- Air knives should be applied to the entry and exit points to continuous dryers (to prevent vapour loss, contamination and dust emissions).
- Lights/signs should clearly indicate when the dryer is in use.
- Exhaust ventilation systems should be easily controllable, interlocked to the dryer heating controls and fitted with warning lights/alarms. Refer to task guidance sheet **2.1.13**.
- When the dryer is in use, the extraction should be balanced to a minimum level to maintain a slight negative pressure within the dryer.
- **When feeding or unloading the dryer, avoid any friction of the products to be dried (design of transportation units).**
- Where possible, locate the work area away from doors, windows and walkways to stop draughts interfering with the ventilation and spreading dust.
- Provide an air supply to the workroom to replace extracted air.
- Provide an easy way of checking the control is working, e.g. a manometer, pressure gauge or tell-tale (a small flag).
- Discharge extracted air to a safe place away from doors, windows and air inlets.
- **Air recirculation is not recommended.**

MAINTENANCE

- Ensure equipment used in the task is maintained as advised by the supplier/installer in efficient working order and in good repair.
- Replace consumables (filters etc.) in accordance with the manufacturer's recommendations.



EXAMINATION AND TESTING

- Obtain information on the design performance of the ventilation equipment from the supplier. Keep this information to compare with future test results.
- Visually check all equipment at least once per week for signs of damage or, if it is in constant use, check it more frequently. If used infrequently, then check it before each use.
- Have the ventilation equipment examined and tested against its performance standard, at least once each year.
- Keep records of inspections for a suitable period of time which complies with national laws (minimum five years).
- Put in place measures to control the risk of bacterial growth within water sources used across site, focusing most on systems where water droplets will be generated.

CLEANING AND HOUSEKEEPING

- Clean your workplace and equipment on a regular basis.
- Deal with spills immediately.
- Use vacuum or wet cleaning methods.
- **DO NOT clean up with a dry brush or using compressed air.**

TRAINING

- Give your employees information on the health effects associated with respirable crystalline silica dust.
- Provide employees with training on: dust exposure prevention; checking controls are working and using them; when and how to use any respiratory protective equipment provided and what to do if something goes wrong. Refer to task guidance sheet **2.3.4** and part 1 of the Good Practice Guide.

SUPERVISION

- Have a system to check that control measures are in place and that they are being followed. Refer to task guidance sheet **2.3.3**.
- Employers should make sure that employees have all the means to perform the checklist given below.

PERSONAL PROTECTIVE EQUIPMENT

- Refer to task guidance sheet **2.1.15** dedicated to Personal Protective Equipment.
- Risk assessment must be carried out to determine whether existing controls are adequate. If necessary, respiratory protective equipment (with the appropriate protection factor) should be provided and worn.
- Provide storage facilities to keep personal protective equipment clean when not in use.
- Replace personal protective equipment at intervals recommended by the manufacturer/supplier.

EMPLOYEE CHECKLIST

- | | | | |
|--|--|--|---|
| <input type="checkbox"/> Make sure the ventilation system is switched on and is working. | <input type="checkbox"/> If you think there is a problem with your dust control equipment, ensure additional control measures are taken to reduce exposure to respirable crystalline silica dust while the problem persists. | <input type="checkbox"/> Remove broken products immediately from feeding units. | <input type="checkbox"/> Use, maintain and store any respiratory protective equipment provided in accordance with instructions. |
| <input type="checkbox"/> Make sure it is running properly; check the manometer, pressure gauge or tell-tale. | | <input type="checkbox"/> Clear up spills immediately. Use vacuum cleaning or wet cleaning methods. Dispose of spills safely. | <input type="checkbox"/> Check and implement the measures to control the risk of bacterial growth within water sources used across site, focusing most on systems where water droplets will be generated. |
| <input type="checkbox"/> Look for signs of damage, wear or poor operation of any equipment used. If you find any problems, tell your supervisor. | | <input type="checkbox"/> Do not clean up with a dry brush or using compressed air. | |

This guidance sheet is aimed at employers to help them comply with the requirements of workplace health and safety legislation, by controlling exposure to respirable crystalline silica. Specifically, this sheet provides good practice advice on dust control during drying of shaped fine and coarse ceramics made of materials containing crystalline silica. The drying process can be periodic or continuous.

Following the key points of this task guidance sheet will help reduce exposure.

Depending on the specific circumstances of each case, it may not be necessary to

apply all of the control measures identified in this sheet in order to minimise exposure to respirable crystalline silica. i.e. to apply appropriate protection and prevention measures. This document should also be made available to persons who may be exposed to respirable crystalline silica in the workplace, in order that they may make the best use of the control measures which are implemented.

This sheet forms part of the Good Practices Document on silica dust prevention, which is aimed specifically at the control of personal exposure to respirable crystalline silica dust in the workplace.

GOOD PRACTICES FOR TRANSPORT SYSTEMS FOR FINE DRY SILICA PRODUCTS

This activity relates to the design of the transport systems for fine dry silica products.

ACCESS

Restrict access to the work area to authorised personnel only.

DESIGN AND EQUIPMENT

- It is preferable to use enclosed handling systems when transporting silica flour.
- **Pneumatic systems** are appropriate for both horizontal and vertical transport of silica flour.
- For horizontal transport in **pneumatic systems**, pipes should be angled downwards where possible to prevent flour settling in the pipes and causing a blockage in the event system pressure is lost.
- The pipe work in **pneumatic systems** should be designed to minimise unnecessary obstacles and to minimise sharp bends. Pipe connections should be properly sealed.
- For **air slides**, the fluidising air will be drawn away by the dust extraction system. For this reason, air slides cannot be used if the product is too fine. If the surface area is more than 10,000 cm²/g, use screw conveyors. More than one de-dusting connection may be required on long lengths in order to correctly balance airflows.
- **Air slides** should be inclined slightly in order to assist the horizontal transport of silica flour. The quality of the cloth used in air slides should be selected to avoid excessive pressure loss for the fan, whilst also preventing silica flour from falling through the cloth and causing it to become blocked.
- For **screw conveyors**, the screw must be enclosed. Specialist design is required due to the abrasive properties of silica flour (contact an experienced supplier).
- **Screw conveyors** may need to be equipped with dust extraction systems unless they are connected to equipment that already operates under negative pressure. Refer to task guidance sheet **2.1.13**.



- **Conveyor belts are not suitable for the transportation of loose silica flour.** However, they may be used for the transport of other, coarser, materials and in machinery that handles bags of silica flour. Conveyors handling bags of silica flour, or other dusty materials, should be enclosed and equipped with dust extraction.
- **Elevators** are suitable for vertical transport, provided they are fully enclosed. Dust extraction systems may be required unless elevators are connected to equipment that already operates under negative pressure.
- It may be necessary to apply fluidising air at the base of **silos** holding silica flour. Such systems should be designed so that the fluidising air is only applied at times when it is necessary to make the silica flour flow out of the silo. Fluidising air should not be left switched on permanently in situations where the air could migrate and cause silica flour to be emitted under pressure from elsewhere in the system.

GUIDANCE FOR EMPLOYERS ON CONTROLLING EXPOSURE TO RCS IN THE WORKPLACE

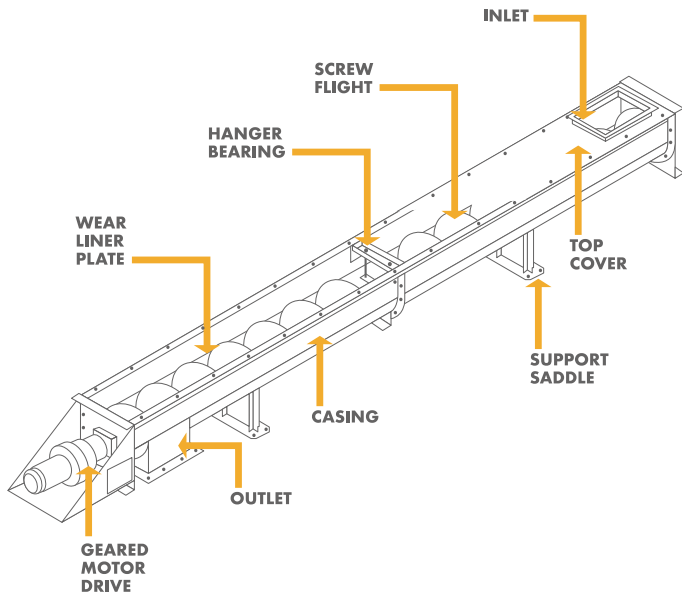

MAINTENANCE

- Ensure equipment used in the task is maintained as advised by the supplier/installer in efficient working order and in good repair.
- Replace consumables (filters etc.) in accordance with the manufacturer’s recommendations.

EXAMINATION AND TESTING

- Visually check the equipment at least once per week for signs of damage or, if it is in constant use, check it more frequently. If used infrequently, then check it before each use.
- Obtain information on the design performance of the dust suppression and/or extraction equipment from the supplier. Keep this information to compare with future test results.
- Keep records of inspections for a suitable period of time which complies with national laws (minimum five years).
- Put in place measures to control the risk of bacterial growth within water sources used across site, focusing most on systems where water droplets will be generated.

CLEANING AND HOUSEKEEPING

- Clean your workplace on a regular basis.
- **DO NOT clean up with a dry brush or using compressed air.**
- Use vacuum or wet cleaning methods.

TRAINING

- Give your employees information on the health effects associated with respirable crystalline silica dust.
- Provide employees with training on: dust exposure prevention; checking controls are working and using them; when and how to use any respiratory protective equipment provided and what to do if something goes wrong. Refer to task guidance sheet **2.3.4** and part 1 of the Good Practice Guide.

SUPERVISION

- Have a system to check that control measures are in place and that they are being followed. Refer to task guidance sheet **2.3.3**.
- Employers should make sure that employees have all the means to perform the checklist given on the following page.

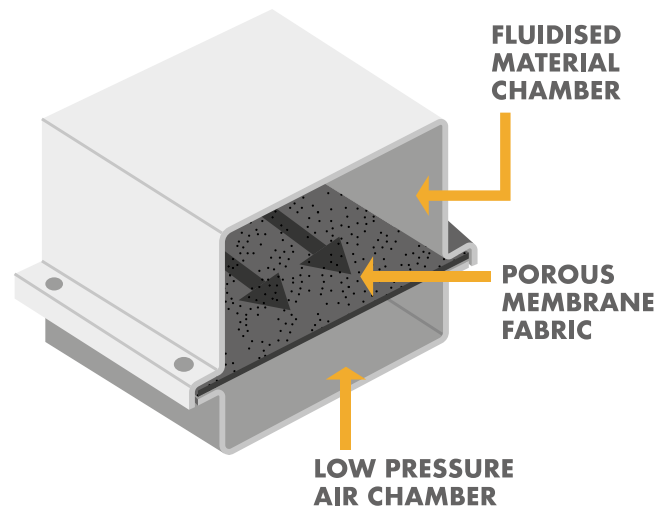

PERSONAL PROTECTIVE EQUIPMENT

- Refer to task guidance sheet **2.1.15** dedicated to Personal Protective Equipment.
- Provide pictograms on doors to indicate areas where respiratory protective equipment must be worn.
- Provide storage facilities to keep personal protective equipment clean when not in use.
- Provide enough places where Personal protective equipment can be found (e.g. box with disposable dust masks). Indicate those places with pictograms.

EMPLOYEE CHECKLIST

- | | | | |
|--|--|---|---|
| <input type="checkbox"/> Look for signs of damage or wear of building parts and of your work equipment. If you find any problems, tell your supervisor. | <input type="checkbox"/> If you think there is a problem with your dust control equipment, ensure additional control measures are taken to reduce exposure to respirable crystalline silica dust while the problem persists. | <input type="checkbox"/> Clean up control cabins using vacuum or wet cleaning methods. | <input type="checkbox"/> Check and implement the measures of controlling the risk of bacterial growth within water sources used across site, focusing most on systems where water droplets will be generated. |
| <input type="checkbox"/> Problems with silica flour transportation systems may be indicated by emissions of dust into the workplace air and by the appearance of piles of silica flour on floors and surfaces. Report any of these to your supervisor. | <input type="checkbox"/> Clear up spills straight away. Use vacuum cleaning or wet mopping. Dispose of spills safely. | <input type="checkbox"/> Use, maintain and store any respiratory protective equipment provided in accordance with instructions. | |

This guidance sheet is aimed at employers to help them comply with the requirements of workplace health and safety legislation, by controlling exposure to respirable crystalline silica. Specifically, this sheet provides advice on the design of transport systems for silica flour products.

Following the key points of this task guidance sheet will help reduce exposure.

Depending on the specific circumstances of each case, it may not be necessary to apply all of the control measures identified in this sheet in order to minimise exposure

to respirable crystalline silica. i.e. to apply appropriate protection and prevention measures. This document should also be made available to persons who may be exposed to respirable crystalline silica in the workplace, in order that they may make the best use of the control measures which are implemented.

This sheet forms part of the Good Practices Guide on silica dust prevention, which is aimed specifically at the control of personal exposure to respirable crystalline silica dust in the workplace.