

GOOD PRACTICES FOR BAG EMPTYING – SMALL BAGS

This sheet provides advice on emptying of small bags of products containing crystalline silica in a production unit, particularly those containing dry materials.

ACCESS

Restrict access to the work area to authorised personnel only.

DESIGN AND EQUIPMENT

- Ensure bag emptying equipment is fit for purpose.
- Enclose the bag emptying equipment as much as possible and keep it under negative pressure by using a local exhaust ventilation system – refer to task guidance sheet **2.1.13**.
- For small bags, the use of automatic or semi-automatic bag dumping stations is recommended for emptying the bags.
- Ensure workers tip the bag contents gently – never dump them. Bags should be emptied with the open end facing away.
- Bag crushing creates a lot of dust. Workers should roll up empty bags within the extraction zone.
- In order to dispose of empty bags without creating dust, drop them into a large plastic sack supported and held open by a metal frame. When it is full, seal the sack and dispose of it in a suitable waste skip. **DO NOT let the waste sack overflow.** Alternatively, use a compactor equipped with a dust extraction system or which is fully enclosed.
- Bag emptying equipment should be connected to a suitable dust arrestment system (e.g. bag filter/cyclone). A permanent dust extraction system is preferred, though a stand-alone mobile unit is acceptable.
- Bag emptying equipment should be designed for easy access to all parts for maintenance, unblocking and cleaning. Access panels should be interlocked or have trip devices where necessary to prevent persons accessing dangerous parts of machinery.

- Consider providing mechanical/pneumatic assistance with bag handling.
- Where possible keep bag emptying equipment away from doors, windows and walkways to prevent draughts affecting the performance of dust extraction systems.
- Provide a clean air supply to the workroom to replace extracted air.

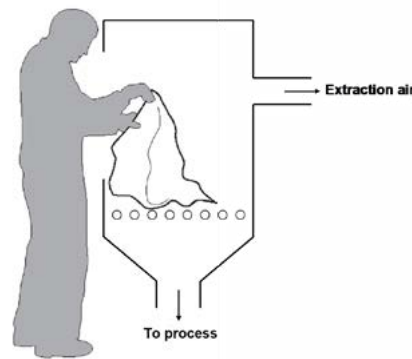

Manual Bag Emptying

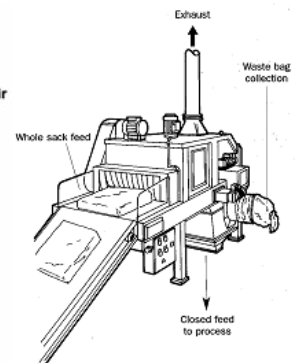

Automated Bag Emptying

MAINTENANCE

- Ensure equipment used in the task is maintained as advised by the supplier/installer in efficient working order and in good repair.
- Replace consumables (filters etc.) in accordance with the manufacturer's recommendations.

EXAMINATION AND TESTING

- Visually check the cleaning equipment for signs of damage at least once per week or, if it is in constant use, check it more frequently. If used infrequently, then check it before each use.
- Obtain information on the design performance of dust suppression and/or extraction equipment from the supplier. Keep this information to compare with future test results.
- Keep records of inspections for a suitable period of time which complies with national laws (minimum five years).
- Put in place measures to control the risk of bacterial growth within water sources used across site, focusing most on systems where water droplets will be generated.

CLEANING AND HOUSEKEEPING

- Clean your workplace on a regular basis.
- Deal with spills immediately.
- **DO NOT clean up with a dry brush or using compressed air.**
- Use vacuum or wet cleaning methods.

TRAINING

- Give your employees information on the health effects associated with respirable crystalline silica dust.

- Provide employees with training on: dust exposure prevention; checking controls are working and using them; when and how to use any respiratory protective equipment provided and what to do if something goes wrong. Refer to task guidance sheet **2.3.4** and part 1 of the Good Practice Guide.

SUPERVISION

- Have a system to check that control measures are in place and that they are being followed. Refer to task guidance sheet **2.3.3**.
- Employers should make sure that employees have all the means to perform the checklist given below.

PERSONAL PROTECTIVE EQUIPMENT

- Refer to task guidance sheet **2.1.15** dedicated to Personal Protective Equipment.
- Risk assessment must be carried out to determine whether existing controls are adequate. If necessary, respiratory protective equipment (with the appropriate protection factor) should be provided and worn.
- Provide storage facilities to keep personal protective equipment clean when not in use.
- Replace respiratory protective equipment at intervals recommended by its suppliers.

EMPLOYEE CHECKLIST

- | | | | |
|---|--|---|---|
| <input type="checkbox"/> Make sure the ventilation system is working properly. Make sure the dust extraction system is switched on and is working correctly before starting work. | <input type="checkbox"/> If you think there is a problem with your dust control equipment, ensure additional control measures are taken to reduce exposure to respirable crystalline silica dust while the problem persists. | <input type="checkbox"/> Use handling aids when available. | <input type="checkbox"/> Use, maintain and store any respiratory protective equipment provided in accordance with instructions. |
| <input type="checkbox"/> Look for signs of damage, wear or poor operation of any equipment used. If you find any problems, tell your supervisor. | | <input type="checkbox"/> Clear up spills straight away. Use vacuum or wet cleaning methods. | <input type="checkbox"/> Check and implement the measures of controlling the risk of bacterial growth within water sources used across site, focusing most on systems where water droplets will be generated. |
| | | <input type="checkbox"/> Clean up work rooms using vacuum or wet cleaning techniques. | |

This guidance sheet is aimed at employers to help them comply with the requirements of workplace health and safety legislation, by controlling exposure to respirable crystalline silica. Specifically, this sheet provides good practice advice on dust control during small bag emptying operations.

Following the key points of this task guidance sheet will help reduce exposure.

Depending on the specific circumstances of each case, it may not be necessary to apply all of the control measures identified in this sheet in order to minimise exposure

to respirable crystalline silica. i.e. to apply appropriate protection and prevention measures. This document should also be made available to persons who may be exposed to respirable crystalline silica in the workplace, in order that they may make the best use of the control measures which are implemented.

This sheet forms part of the Good Practices Guide on silica dust prevention, which is aimed specifically at the control of personal exposure to respirable crystalline silica dust in the workplace.

GOOD PRACTICES FOR BAG EMPTYING – BULK BAGS

This sheet provides advice on how to empty bulk bags (big bags) of products containing crystalline silica in a production unit, particularly those containing dry materials.

ACCESS

Restrict access to the work area to authorised personnel only.

DESIGN AND EQUIPMENT

- Ensure bag emptying equipment is fit for purpose.
- Enclose the bag emptying equipment as much as possible and keep it under negative pressure by using a local exhaust ventilation system – refer to task guidance sheet **2.1.13**.
- **Manual bag cutting is not recommended without the use of personal protective equipment.**
- For single trip bulk bags without inner liner, use bag emptying equipment featuring pyramidal cutting knives and a rubber membrane to seal off the bag bottom.
- For multiple trip bulk bags, a discharge system with vibrator plate should be used and this should be equipped with local exhaust ventilation.
- Where multiple trip bulk bags are used, which have inner liners, special dust-free outlet connection systems are available which have double ring seals and fully enclosed product discharge.
- In order to dispose of empty bags without creating dust, do not manually compress the empty bags. Instead, drop them into a large plastic sack supported and held open by a metal frame. When it is full, seal the sack and dispose of it in a suitable waste skip. **DO NOT let the waste sack overflow.** Alternatively, use a compactor equipped with a dust extraction system or which is fully enclosed.
- Bag emptying equipment should be connected to a suitable dust arrestment system (e.g. bag filter/cyclone)
- Bag emptying equipment should be designed for easy access to all parts for maintenance, unblocking and cleaning. Access panels should be interlocked or have trip devices where necessary to prevent persons accessing dangerous parts of machinery.

- Consider providing mechanical/pneumatic assistance with bag handling.
- Where possible keep bag emptying equipment away from doors, windows and walkways to prevent draughts affecting the performance of dust extraction systems.
- Provide a clean air supply to the workroom to replace extracted air.

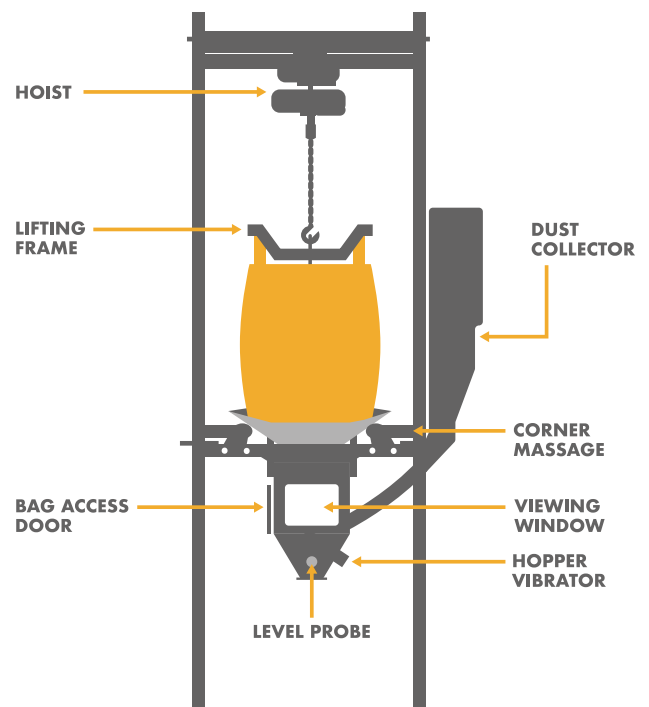

MAINTENANCE

- Ensure equipment used in the task is maintained as advised by the supplier/installer in efficient working order and in good repair.
- Replace consumables (filters etc.) in accordance with the manufacturer's recommendations.

EXAMINATION AND TESTING

- Visually check the cleaning equipment for signs of damage at least once per week or, if it is in constant use, check it more frequently. If used infrequently, then check it before each use.
- Obtain information on the design performance of dust suppression and/or extraction equipment from the supplier. Keep this information to compare with future test results.
- Keep records of inspections for a suitable period of time which complies with national laws (minimum five years).
- Put in place measures to control the risk of bacterial growth within water sources used across site, focusing most on systems where water droplets will be generated.

CLEANING AND HOUSEKEEPING

- Clean your workplace on a regular basis.
- Deal with spills immediately.
- **DO NOT clean up with a dry brush or using compressed air.**
- Use vacuum or wet cleaning methods.

TRAINING

- Give your employees information on the health effects associated with respirable crystalline silica dust.

- Provide employees with training on: dust exposure prevention; checking controls are working and using them; when and how to use any respiratory protective equipment provided and what to do if something goes wrong. Refer to task guidance sheet **2.3.4** and part 1 of the Good Practice Guide.

SUPERVISION

- Have a system to check that control measures are in place and that they are being followed. Refer to task guidance sheets **2.3.3**.
- Employers should make sure that employees have all the means to perform the checklist given below.

PERSONAL PROTECTIVE EQUIPMENT

- Refer to task guidance sheet **2.1.15** dedicated to Personal Protective Equipment.
- Risk assessment must be carried out to determine whether existing controls are adequate. If necessary, respiratory protective equipment (with the appropriate protection factor) should be provided and worn.
- Provide storage facilities to keep personal protective equipment clean when not in use.
- Replace respiratory protective equipment at intervals recommended by its suppliers.

EMPLOYEE CHECKLIST

- | | | | |
|---|--|---|---|
| <input type="checkbox"/> Make sure the ventilation system is working properly. Make sure the dust extraction system is switched on and is working correctly before starting work. | <input type="checkbox"/> If you think there is a problem with your dust control equipment, ensure additional control measures are taken to reduce exposure to respirable crystalline silica dust while the problem persists. | <input type="checkbox"/> Clear up spills straight away. Use vacuum or wet cleaning methods. | <input type="checkbox"/> Check and implement the measures of controlling the risk of bacterial growth within water sources used across site, focusing most on systems where water droplets will be generated. |
| <input type="checkbox"/> Look for signs of damage, wear or poor operation of any equipment used. If you find any problems, tell your supervisor. | <input type="checkbox"/> Use handling aids when available. | <input type="checkbox"/> Clean up control rooms using vacuum or wet cleaning techniques. | |
| | | <input type="checkbox"/> Use, maintain and store any respiratory protective equipment provided in accordance with instructions. | |

This guidance sheet is aimed at employers to help them comply with the requirements of workplace health and safety legislation, by controlling exposure to respirable crystalline silica. Specifically, this sheet provides good practice advice on dust control during bulk bag emptying operations.

Following the key points of this task guidance sheet will help reduce exposure.

Depending on the specific circumstances of each case, it may not be necessary to apply all of the control measures identified in this sheet in order to minimise exposure

to respirable crystalline silica. i.e. to apply appropriate protection and prevention measures. This document should also be made available to persons who may be exposed to respirable crystalline silica in the workplace, in order that they may make the best use of the control measures which are implemented.

This sheet forms part of the Good Practices Guide on silica dust prevention, which is aimed specifically at the control of personal exposure to respirable crystalline silica dust in the workplace.

GOOD PRACTICES FOR BULK ROAD TANKER LOADING

This activity covers bulk loading operations for road tanker transport of products containing crystalline silica, particularly those containing dry materials.

ACCESS

Restrict access to the work area to authorised personnel only.

DESIGN AND EQUIPMENT

- Ensure the loading equipment is adequate and well maintained.
- Provide a loading bellow chute capable of extracting enough air to keep the loading point under negative pressure.
- The loading bellow should be connected to a suitable dust extraction system (e.g. a bag filter/cyclone).
- Make arrangements to discharge the air, which is displaced during loading of bulk products, so that it can not escape from the vessel.
- Provide where possible closed and depressurised transport equipment with adequate de-dusting equipment.
- Where possible, incline de-dusting ducts so as to avoid settling of dust. Ensure minimal internal wear on ducts by selecting wear resistant materials, using adequate duct dimensions and by avoiding sharp bends.
- Design ducts with appropriate internal diameter (increasing as one approaches the de-dusting system) in order to maintain adequate transport velocities and to prevent settling of dust.
- Try to avoid leakages as much as possible.
- Control cabins should have their own clean air supply, or may be fitted with forced air filtration.



MAINTENANCE

- Ensure equipment used in the task is maintained as advised by the supplier/installer in efficient working order and in good repair.
- Replace consumables (filters etc.) in accordance with the manufacturer’s recommendations.

EXAMINATION AND TESTING

- Visually check the cleaning equipment for signs of damage at least once per week or, if it is in constant use, check it more frequently. If used infrequently, then check it before each use.
- Obtain information on the design performance of the dust suppression and/or extraction equipment from the supplier. Keep this information to compare with future test results.
- Keep records of inspections for a suitable period of time which complies with national laws (minimum five years).
- Put in place measures of controlling the risk of bacterial growth within water sources used across site, focusing most on systems where water droplets will be generated.

CLEANING AND HOUSEKEEPING

- Clean your workplace on a regular basis.
- **DO NOT clean up with a dry brush or using compressed air.**
- Use vacuum or wet cleaning methods.

TRAINING

- Give your employees information on the health effects associated with respirable crystalline silica dust.
- Provide employees with training on: dust exposure prevention; checking controls are working and using them; when and how to use any respiratory protective equipment provided and what to do if something goes wrong. Refer to task guidance sheet **2.3.4** and part 1 of the Good Practice Guide.

SUPERVISION

- Have a system to check that control measures are in place and that they are being followed. Refer to task guidance sheet **2.3.3**.
- Employers should make sure that employees have all the means to perform the checklist given below.

PERSONAL PROTECTIVE EQUIPMENT

- Refer to task guidance sheet **2.1.15** dedicated to Personal Protective Equipment.
- Risk assessment must be carried out to determine whether existing controls are adequate. If necessary, respiratory protective equipment (with the appropriate protection factor) should be provided and worn.
- Provide storage facilities to keep personal protective equipment clean when not in use.
- Replace respiratory protective equipment at intervals recommended by its suppliers.

EMPLOYEE CHECKLIST

- | | | | |
|---|--|---|---|
| <input type="checkbox"/> Make sure the loading equipment is working properly. Make sure the dust extraction system is switched on and is working. | <input type="checkbox"/> If you think there is a problem with your dust control equipment, ensure additional control measures are taken to reduce exposure to respirable crystalline silica dust while the problem persists. | <input type="checkbox"/> Clear up spills straight away. Use vacuum or wet cleaning methods. | <input type="checkbox"/> Check and implement the measures of controlling the risk of bacterial growth within water sources used across site, focusing most on systems where water droplets will be generated. |
| <input type="checkbox"/> Look for signs of damage, wear or poor operation of any equipment used. If you find any problems, tell your supervisor. | <input type="checkbox"/> Use handling aids when available. | <input type="checkbox"/> Clean up any control cabin using vacuum or wet cleaning methods. | |
| | | <input type="checkbox"/> Use, maintain and store any respiratory protective equipment provided in accordance with instructions. | |

This guidance sheet is aimed at employers to help them comply with the requirements of workplace health and safety legislation, by controlling exposure to respirable crystalline silica. Specifically, this sheet provides good practice advice on dust control during bulk loading operations for road tanker transport.

Following the key points of this task guidance sheet will help reduce exposure.

Depending on the specific circumstances of each case, it may not be necessary to apply all of the control measures identified in this sheet in order to minimise exposure

to respirable crystalline silica. i.e. to apply appropriate protection and prevention measures. This document should also be made available to persons who may be exposed to respirable crystalline silica in the workplace, in order that they may make the best use of the control measures which are implemented.

This sheet forms part of the Good Practices Guide on silica dust prevention, which is aimed specifically at the control of personal exposure to respirable crystalline silica dust in the workplace.

GOOD PRACTICES FOR BULK LOADING

This activity covers bulk loading operations for road (except road tankers), rail and water transport of crystalline silica containing materials particularly dry materials.

Task guidance sheet **2.2.3a** offers advice on loading of road tankers.

ACCESS

Restrict access to the work area to authorised personnel only.

DESIGN AND EQUIPMENT

- Ensure that all loading equipment is fit for purpose and well maintained.
- Appropriate techniques may include the use of conveyors, screw feeds, grabs, bucket elevators, hoppers, chutes and fill pipes.
- Enclose conveyors, chutes etc. as much as possible.
- Minimise the speed of descent of the material:
 - Minimise falling distances – design chutes etc. so that the material cascades. i.e. several short descents rather than one big one.
 - Install baffles inside long fill pipes.
 - Minimise slope angles in chutes, fill pipes etc.
- **DO NOT load flour products in the open air; enclosed systems must be used.**
- Loading facilities should be sheltered to prevent dust being generated by the wind, whilst also providing a good standard of through-ventilation.
- Control cabins should be well-sealed and have their own clean air supply. Where necessary, they should be equipped with forced air filtration and maintained under positive pressure.
- CCTV systems can be used to reduce the need for operators to visit dusty areas.
- See task guidance sheet **2.2.3a** entitled “Bulk Road Tanker Loading” for advice on loading of road tankers.

MAINTENANCE

- Ensure equipment used in the task is maintained as advised by the supplier/installer in efficient working order and in good repair.
- Replace consumables (filters etc.) in accordance with the manufacturer’s recommendations.



EXAMINATION AND TESTING

- Visually check the cleaning equipment for signs of damage at least once per week or, if it is in constant use, check it more frequently. If used infrequently, then check it before each use.
- Obtain information on the design performance of ventilation equipment from the supplier. Keep this information to compare it with future test results.
- Keep records of inspections for a suitable period of time which complies with national laws (minimum five years).
- Put in place measures of controlling the risk of bacterial growth within water sources used across site, focusing most on systems where water droplets will be generated.

CLEANING AND HOUSEKEEPING

- Clean your workplace on a regular basis.
- Deal with spills immediately.
- **DO NOT clean up with a dry brush or using compressed air.**
- Use vacuum or wet cleaning methods.

TRAINING

- Give your employees information on the health effects associated with respirable crystalline silica dust.
- Provide employees with training on: dust exposure prevention; checking controls are working and using them; when and how to use any respiratory protective equipment provided and what to do if something goes wrong. Refer to task guidance sheet **2.3.4** and part 1 of the Good Practice Guide.
- Ensure that transport operators are provided with copies of loading procedures and training as necessary.

SUPERVISION

- Have a system to check that control measures are in place and that they are being followed. Refer to task guidance sheet **2.3.3**.
- Employers should make sure that employees have all the means to perform the checklist given below.

PERSONAL PROTECTIVE EQUIPMENT

- Refer to task guidance sheet **2.1.15** dedicated to Personal Protective Equipment.
- Risk assessment must be carried out to determine whether existing controls are adequate. If necessary, respiratory protective equipment (with the appropriate protection factor) should be provided and worn.
- Indicate the need for respiratory protective equipment to be worn using appropriate pictogram signs.
- Provide storage facilities to keep personal protective equipment clean when not in use.
- Replace respiratory protective equipment at intervals recommended by its suppliers.

EMPLOYEE CHECKLIST

- | | | | |
|--|---|---|---|
| <input type="checkbox"/> Make sure the loading equipment is working properly. | <input type="checkbox"/> Look for signs of damage, wear or poor operation of any equipment used. If you find any problems, tell your supervisor. | <input type="checkbox"/> Clear up spills straight away. Use vacuum or wet cleaning methods. | <input type="checkbox"/> Check and implement the measures of controlling the risk of bacterial growth within water sources used across site, focusing most on systems where water droplets will be generated. |
| <input type="checkbox"/> Make sure the ventilation system is switched on and is working. | <input type="checkbox"/> If you think there is a problem with your dust control equipment, ensure additional control measures are taken to reduce exposure to | <input type="checkbox"/> Use, maintain and store any respiratory protective equipment provided in accordance with instructions. | |
| <input type="checkbox"/> Wear respiratory protective equipment (e.g. a dust mask) in areas where this has been deemed necessary. | | | |

This guidance sheet is aimed at employers to help them comply with the requirements of workplace health and safety legislation, by controlling exposure to respirable crystalline silica. Specifically, this sheet provides good practice advice on dust control during bulk loading operations for road (except road tankers), railway and ship transport.

Following the key points of this task guidance sheet will help reduce exposure.

Depending on the specific circumstances of each case, it may not be necessary to

apply all of the control measures identified in this sheet in order to minimise exposure to respirable crystalline silica. i.e. to apply appropriate protection and prevention measures. This document should also be made available to persons who may be exposed to respirable crystalline silica in the workplace, in order that they may make the best use of the control measures which are implemented.

This sheet forms part of the Good Practices Guide on silica dust prevention, which is aimed specifically at the control of personal exposure to respirable crystalline silica dust in the workplace.

GOOD PRACTICES FOR BULK ROAD TANKER UNLOADING (BLOWING OFF)

This activity covers the discharge of silica sand and flour products from a road tanker into a storage silo, particularly dry materials.

ACCESS

Restrict access to the work area to authorised personnel only.

DESIGN AND EQUIPMENT

Road Tanker

- Limit the discharge rate to the design capacity of the receiving silo and dust extraction unit. Offloading pressures should be agreed with the silo operator.
- Tanker offloading pipes, connectors and seals must be designed to withstand the high air pressures and abrasion associated with blowing operations.
- Note that there will be a surge of air pressure as the last sand/flour is blown into a silo. Hence the need for constant supervision of offloading operations.

Customer silo

- Storage silos should be purchased only from reputable suppliers.
- Appropriate engineering design methods should be employed to ensure adequate structural strength.
- Engineering controls must be employed to prevent over-pressurisation of the silo while it is being filled. Ensure that the silos are equipped with pressure relief devices and high level alarms. They must also have dust extraction systems to remove and clean the displaced air.
- Silo dust extraction units must be fitted with filters that are appropriate to the particle size range of the product.
- Offloading pressures should be agreed with the tanker operator.
- Note that flour products have varying bulk density. Put in place procedures to ensure that silos are not overfilled.
- Silos should be equipped with a dust extraction system to prevent the emission of dust from the silo during tanker offloading.

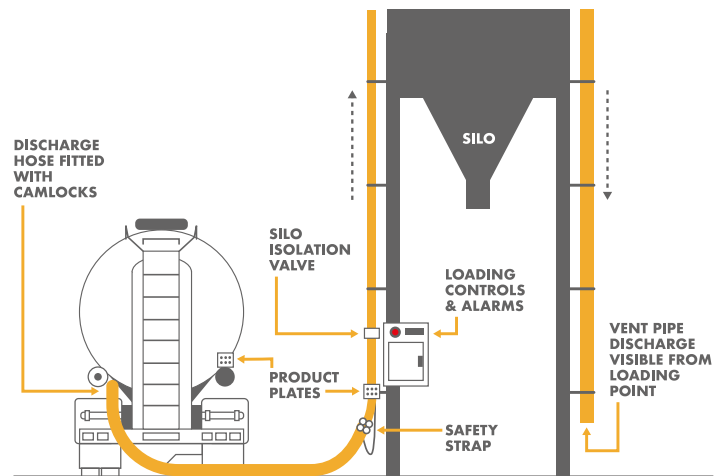

- Pipework and ductwork should be designed to minimise shock losses (caused by bends, constrictions etc.); to minimise dead spots where material may accumulate and to facilitate easy clearing of blockages.
- Silo connection points should be located as close as possible to the delivery tanker parking area. This will eliminate the need for long lengths of flexible hose.
- Safe means of access should be provided to those parts of the silo requiring inspection and maintenance.

MAINTENANCE

- Maintain pipes/hoses, connectors and seals in good condition to reduce the likelihood of dust escaping during blowing operations.
- Dust extraction systems on silos must be maintained in accordance with manufacturers' instructions.

EXAMINATION AND TESTING

- A competent person should test the performance of dust extraction systems at least annually.
- Tanker drivers should check the condition of pipes/hoses and seals daily and obtain replacements as necessary.
- Any faults with the pipes/hoses/connectors and silo dust extraction systems must be reported as soon as possible so that remedial action can be taken.
- Put in place measures of controlling the risk of bacterial growth within water sources used across site, focusing most on systems where water droplets will be generated.

CLEANING AND HOUSEKEEPING

- The tanker offloading area should be kept clean and tidy.
- Clean your workplace on a regular basis.
- Deal with spills immediately.
- **DO NOT clean up with a dry brush or using compressed air.**
- Use vacuum or wet cleaning methods.

TRAINING

- Give your employees information on the health effects associated with respirable crystalline silica dust.

- Provide employees with training on: dust exposure prevention; checking controls are working and using them; when and how to use any respiratory protective equipment provided and what to do if something goes wrong. Refer to task guidance sheet **2.3.4** and part 1 of the Good Practice Guide.

SUPERVISION

- Ensure procedures are in place to prevent overfilling of silos.
- Have a system to check that dust control measures are in place and that they are being followed. Refer to task guidance sheet **2.3.3**.
- Employers should make sure that employees have all the means to perform the checklist given below.

PERSONAL PROTECTIVE EQUIPMENT

- Refer to task guidance sheet **2.1.15** dedicated to Personal Protective Equipment.
- Risk assessment must be carried out to check the effectiveness of control measures.
- Respiratory protective equipment (with the appropriate protection factor) may need to be worn when disconnecting the offloading pipe at the back of the tanker, when remedying any escape of dust or in the event control measures fail.
- Provide storage facilities to keep personal protective equipment clean when not in use. Replace this equipment at intervals recommended by suppliers.

EMPLOYEE CHECKLIST

- | | | | |
|--|--|--|---|
| <input type="checkbox"/> Tanker drivers must supervise their offloading operations at all times. | <input type="checkbox"/> Look for signs of damage, wear or poor operation of any equipment used. If you find any problems, tell your supervisor. | <input type="checkbox"/> Clean up spillages of sand and flour immediately, using wet cleaning methods. | <input type="checkbox"/> Use, maintain and store any respiratory protective equipment provided in accordance with instructions. |
| <input type="checkbox"/> Agree offloading pressures with the customer. | <input type="checkbox"/> If you think there is a problem with your dust control equipment, ensure additional control measures are taken to reduce exposure to respirable crystalline silica dust while the problem persists. | <input type="checkbox"/> Wear a dust mask when it is necessary to enter dusty areas in order to rectify any escape of dust, or in the event other control measures fail. | <input type="checkbox"/> Check and implement the measures of controlling the risk of bacterial growth within water sources used across site, focusing most on systems where water droplets will be generated. |
| <input type="checkbox"/> Check the condition of pipes, hoses and connectors daily. | | | |

This guidance sheet is aimed at employers to help them comply with the requirements of workplace health and safety legislation, by controlling exposure to respirable crystalline silica. Specifically, this sheet provides advice on how to minimise the release of airborne dust when blowing off a road tanker of silica sand or flour.

Following the key points of this task guidance sheet will help reduce exposure.

Depending on the specific circumstances of each case, it may not be necessary to apply all of the control measures identified in this sheet in order to minimise exposure

to respirable crystalline silica. i.e. to apply appropriate protection and prevention measures. This document should also be made available to persons who may be exposed to respirable crystalline silica in the workplace, in order that they may make the best use of the control measures which are implemented.

This sheet forms part of the Good Practices Guide on silica dust prevention, which is aimed specifically at the control of personal exposure to respirable crystalline silica dust in the workplace.

GOOD PRACTICES FOR BULK UNLOADING

This activity covers bulk unloading operations for road (except road tankers), rail and water transport of crystalline silica containing materials, particularly dry materials. Sheet **2.2.4a** offers advice on unloading of road tankers.

ACCESS

Restrict access to the work area to authorised personnel only.

DESIGN AND EQUIPMENT

- Ensure that all unloading equipment is fit for purpose and well maintained.
- When discharging dry products, install dust extraction systems in areas where dust may be emitted into the workplace air.
- Consider isolating the discharge area and keeping it under negative pressure. Alternatively, provide control rooms which are sealed and kept under positive pressure.
- The truck driver should remain in the cab of the truck during unloading with the doors and windows closed. Where possible, a HEPA filter should be incorporated in the cab's HVAC system.
- Design the size and shape of receiving hoppers so that they are appropriate to the capacity of the road haulage vehicles, rail wagons, grabs etc feeding them.
- Prepare offloading procedures. Ensure that hoppers and discharge areas are clearly labelled with their contents.
- **DO NOT discharge flour products in the open air; enclosed systems must be used.**
- See task guidance sheet **2.2.4a** entitled "Bulk Road Tanker Unloading" for advice on blowing off dry products from road tankers.

MAINTENANCE

- Ensure equipment used in the task is maintained as advised by the supplier/installer in efficient working order and in good repair.
- Replace consumables (filters etc.) in accordance with the manufacturer's recommendations.



EXAMINATION AND TESTING

- Visually check the cleaning equipment for signs of damage at least once per week or, if it is in constant use, check it more frequently. If used infrequently, then check it before each use.
- Obtain information on the design performance of dust extraction equipment from the supplier. Keep this information to compare it with future test results.
- Keep records of inspections for a suitable period of time which complies with national laws (minimum five years).
- Put in place measures to control the risk of bacterial growth within water sources used across site, focusing most on systems where water droplets will be generated.

CLEANING AND HOUSEKEEPING

- Clean your workplace on a regular basis.
- Deal with spills immediately.
- **DO NOT clean up with a dry brush or using compressed air.**
- Use vacuum or wet cleaning methods.

TRAINING

- Give your employees information on the health effects associated with respirable crystalline silica dust.
- Provide employees with training on: dust exposure prevention; checking controls are working and using them; when and how

to use any respiratory protective equipment provided and what to do if something goes wrong. Refer to task guidance sheet **2.3.4** and part 1 of the Good Practice Guide.

- Ensure that delivery drivers are provided with copies of offloading procedures and training on these as necessary.

SUPERVISION

- Have a system to check that control measures are in place and that they are being followed. Refer to task guidance sheet **2.3.3**.
- Employers should make sure that employees have all the means to perform the checklist given below.

PERSONAL PROTECTIVE EQUIPMENT

- Refer to task guidance sheet **2.1.15** dedicated to Personal Protective Equipment.
- Risk assessment must be carried out to determine whether existing controls are adequate. If necessary, respiratory protective equipment (with the appropriate protection factor) should be provided and worn.
- Indicate the need for respiratory protective equipment to be worn using appropriate pictogram signs.
- Provide storage facilities to keep personal protective equipment clean when not in use.
- Replace respiratory protective equipment at intervals recommended by its suppliers.

EMPLOYEE CHECKLIST

- | | | | |
|--|---|---|---|
| <input type="checkbox"/> Make sure the unloading equipment is working properly. | <input type="checkbox"/> Look for signs of damage, wear or poor operation of any equipment used. If you find any problems, tell your supervisor. | <input type="checkbox"/> Clear up spills straight away. Use vacuum or wet cleaning methods. | <input type="checkbox"/> Check and implement the measures to control the risk of bacterial growth within water sources used across site, focusing most on systems where water droplets will be generated. |
| <input type="checkbox"/> Make sure the dust extraction system is switched on and is working. | <input type="checkbox"/> If you think there is a problem with your dust control equipment, ensure additional control measures are taken to reduce exposure to | <input type="checkbox"/> Use, maintain and store any respiratory protective equipment provided in accordance with instructions. | |
| <input type="checkbox"/> Wear respiratory protective equipment (e.g. a dust mask) in areas where this has been deemed necessary. | | | |

This guidance sheet is aimed at employers to help them comply with the requirements of workplace health and safety legislation, by controlling exposure to respirable crystalline silica. Specifically, this sheet provides good practice advice on dust control during bulk unloading operations.

Following the key points of this task guidance sheet will help reduce exposure.

Depending on the specific circumstances of each case, it may not be necessary to apply all of the control measures identified in this sheet in order to minimise exposure

to respirable crystalline silica. i.e. to apply appropriate protection and prevention measures. This document should also be made available to persons who may be exposed to respirable crystalline silica in the workplace, in order that they may make the best use of the control measures which are implemented.

This sheet forms part of the Good Practices Guide on silica dust prevention, which is aimed specifically at the control of personal exposure to respirable crystalline silica dust in the workplace.

GOOD PRACTICES FOR CRUSHING OF MINERALS/RAW MATERIALS

Large quantities of airborne dust may be generated when minerals containing crystalline silica are fractured during crushing operations.

ACCESS

Restrict access to the work area to authorised personnel only. This will help to protect people from the airborne dust hazard and from other hazards associated with crushing e.g. noise and ejected particles.

DESIGN AND EQUIPMENT

- Control of dust at source should be via enclosure of the process, plus water sprays and/or exhaust ventilation.
- The use of water sprays may not be suitable in all cases, depending on the material/process and also the weather conditions. If necessary to keep the material dry, then enclosure and exhaust ventilation may provide the best option.
- When material is fed by a wheel loader or dumper, flexible strip curtains will help to enclose the crusher loading point.
- Machine controls should be located well away from sources of airborne dust generation.
- If it is necessary for someone to constantly supervise the operation of a crusher, then an enclosed, sealed cab should be provided.
- The use of CCTV systems will enable operators to check the operation of the crusher without being exposed to high dust levels.
- Operator's cabs (control rooms) should be physically separated from dusty areas and fed with clean fresh air, supplied under positive pressure. Alternatively, cabs should be fitted with air conditioning, equipped with an air filter that is designed to withstand a high loading of respirable dust particles.
- In order for the positive pressure supply or air conditioning system to provide the greatest protection from dust exposure, the doors and windows of the cab must be kept closed at all times while the crusher is in operation.

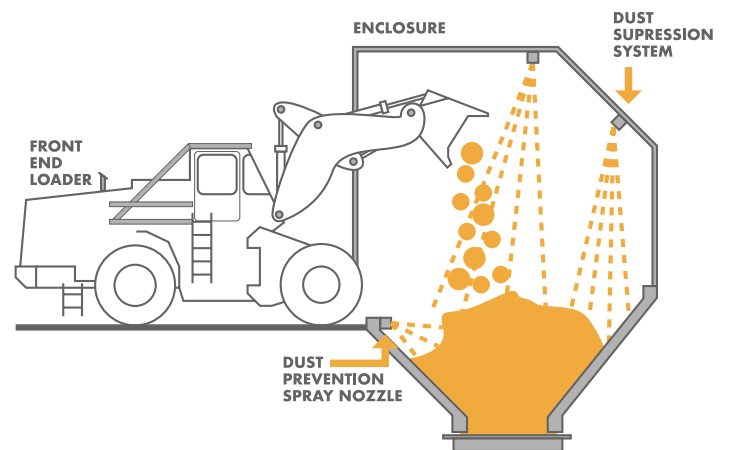

- Timing of crushing operations, to coincide with the wetter seasons of the year, will help to reduce airborne dust generation. Consideration should also be given to the use of water sprays to suppress dust.
- Location of a crusher outdoors will result in better ventilation, thus reducing airborne dust concentrations.
- If a crusher is located inside a building, then a good standard of through ventilation will be required to control dust levels.

MAINTENANCE

- Maintain the cab air conditioning system as advised by the supplier, in effective and efficient working order.
- The air conditioning filter should be changed at the interval (in terms of hours of machine operation) advised by the manufacturer.
- Put in place measures to control the risk of bacterial growth within water sources used across site, focusing most on systems where water droplets will be generated.

EXAMINATION AND TESTING

- Exhaust ventilation systems should be subject to regular examination and testing of their performance according to manufacturer's recommendations and legal requirements.
- Crusher operators should check the condition of the cab air conditioning filter as recommended by manufacturers.
- Any faults with the air conditioning/filtration system must be reported as soon as possible so that remedial action can be taken.
- Keep records of inspections for a suitable period of time which complies with national laws (minimum five years).
- Put in place measures to control the risk of bacterial growth within water sources used across site, focusing most on systems where water droplets will be generated.

CLEANING AND HOUSEKEEPING

- A build up of fine dust on the internal surfaces of the operator's cab might suggest a problem with the air conditioning system.
- Preference should be given to the use of vacuum or wet cleaning methods. Avoid using a dry brush when cleaning the internal surfaces of the operator's cab.

TRAINING

- Give your employees information on the health effects associated with respirable crystalline silica dust.
- Provide employees with training on: dust exposure prevention; checking controls are working and using them; when and how to use any respiratory protective equipment provided and what to do if something goes wrong. Refer to task guidance sheet **2.3.4** and part 1 of the Good Practice Guide.

SUPERVISION

- Have a system to check that control measures are in place and that they are being followed. Refer to task guidance sheet **2.3.3**.
- Employers should make sure that employees have all the means to perform the checklist given below.

PERSONAL PROTECTIVE EQUIPMENT

- Refer to task guidance sheet **2.1.15** dedicated to Personal Protective Equipment.
- Risk assessment must be carried out to check the effectiveness of control measures.
- Provide storage facilities to keep personal protective equipment clean when not in use.
- Replace respiratory protective equipment at intervals recommended by its suppliers.

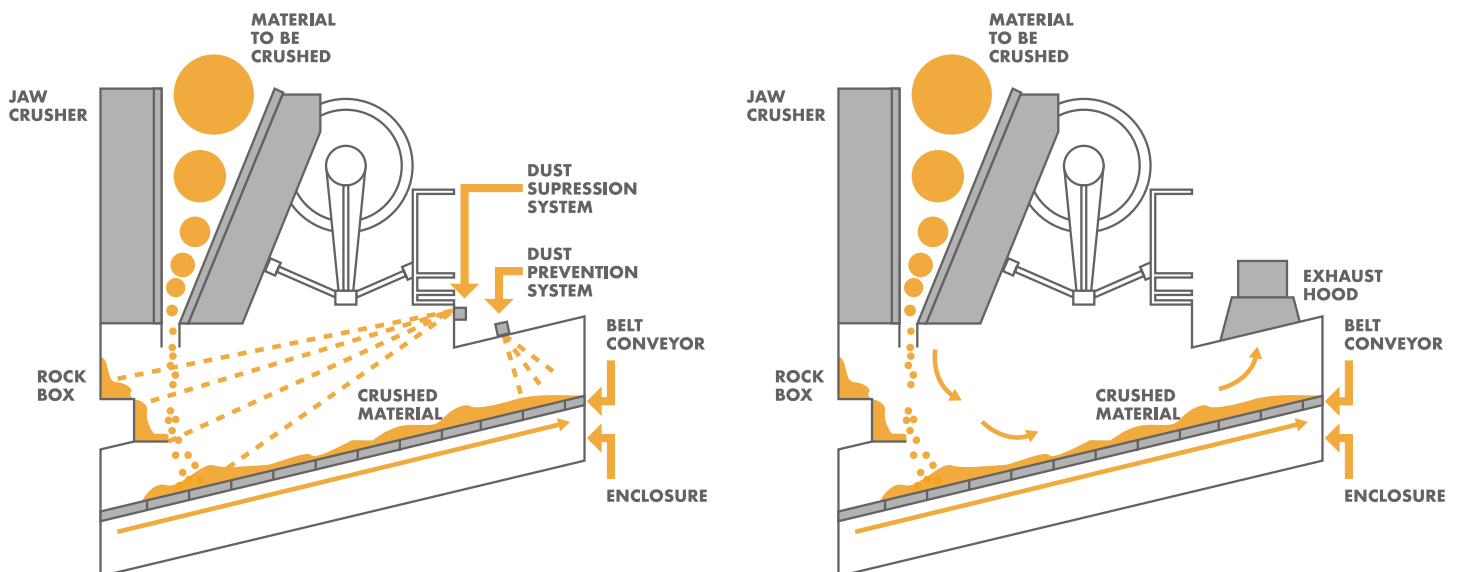

EMPLOYEE CHECKLIST

- Make sure the water sprays and/or exhaust ventilation system are working.
- Keep the cab or control room doors and windows closed at all times when the crusher is in operation.
- Check the condition of the air conditioning filter once a week.
- Keep records of all safety checks on a daily check sheet.
- Look for signs of dust build up on the surfaces of the cab. This may be a sign that the air filter is in poor condition.
- If you think there is a problem with your dust control equipment, ensure additional control measures are taken to reduce exposure to respirable crystalline silica dust while the problem persists.
- Keep the interior of the cab clean.
- Wear a dust mask when it is necessary to enter dusty areas in order to manually split large boulders, during routine plant checks and during maintenance work.
- Use, maintain and store any respiratory protective equipment provided in accordance with instructions.

This guidance sheet is aimed at employers to help them comply with the requirements of workplace health and safety legislation, by controlling exposure to respirable crystalline silica. Specifically, this sheet provides advice on the use of a crusher to break down boulders of quarried material into smaller lumps.

Following the key points of this task guidance sheet will help reduce exposure.

Depending on the specific circumstances of each case, it may not be necessary to apply all of the control measures identified in this sheet in order to minimise exposure

to respirable crystalline silica. i.e. to apply appropriate protection and prevention measures. This document should also be made available to persons who may be exposed to respirable crystalline silica in the workplace, in order that they may make the best use of the control measures which are implemented.

This sheet forms part of the Good Practices Guide on silica dust prevention, which is aimed specifically at the control of personal exposure to respirable crystalline silica dust in the workplace.

GOOD PRACTICES FOR DRYING MINERALS/RAW MATERIALS

This activity covers the operation for drying and cooling of products containing crystalline silica.

ACCESS

Restrict access to the work area to authorised personnel only.

DESIGN AND EQUIPMENT

- Ensure that all drying/cooling equipment is fit for purpose and that it is well maintained.
- The plant should be enclosed as far as possible. Fluid bed dryers are generally more enclosed than rotary dryers.
- Outdoor installation of mineral dryers and coolers will help to reduce personal exposure to respirable crystalline silica dust, by taking advantage of natural ventilation. However, dryers and coolers that are installed outdoors will need to be designed for increased weather resistance.
- In situations where dryers and coolers are installed indoors, forced ventilation may be required in the building in order to ensure adequate dilution and removal of dusty air.
- Install a dust extraction system to serve all points from which dust may escape from the drying/cooling equipment and to maintain the system under negative pressure. This should be connected to a suitable dust extraction unit (e.g. a bag filter, cyclone or wet scrubber).
- Fine dust collected by the dust extraction unit can be returned to the dried product if additional precautions (e.g. closed circuit) are taken to protect those who may be exposed to this dust downstream, for example during bulk loading operations.
- Control cabins should have their own clean air supply. Where necessary, they should be equipped with forced air filtration and maintained under positive pressure. Dryer/cooler controls should be via telemetry in order to reduce the need for operators to visit dusty/noisy areas.
- Mineral dryers and coolers are subject to particulate emission limits and must be designed to satisfy local rules.



MAINTENANCE

- Ensure equipment used in the task is maintained as advised by the supplier/installer in efficient working order and in good repair.
- Replace consumables (filters etc.) in accordance with the manufacturer's recommendations.

EXAMINATION AND TESTING

- Visually check the equipment at least once per week for signs of damage or, if it is in constant use, check it more frequently. If used infrequently, then check it before each use.
- Obtain information on the design performance of the dust suppression and/or extraction equipment from the supplier. Keep this information to compare with future test results.
- Have the equipment examined and tested against its performance standard, at least once each year.
- Keep records of inspections for a suitable period of time which complies with national laws (minimum five years).
- Put in place measures to control the risk of bacterial growth within water sources used across site, focusing most on systems where water droplets will be generated.

CLEANING AND HOUSEKEEPING

- Clean your workplace on a regular basis.
- **DO NOT clean up with a dry brush or using compressed air.**
- Use vacuum or wet cleaning methods.

TRAINING

- Give your employees information on the health effects associated with respirable crystalline silica dust.

- Provide employees with training on: dust exposure prevention; checking controls are working and using them; when and how to use any respiratory protective equipment provided and what to do if something goes wrong. Refer to task guidance sheet **2.3.4** and part 1 of the Good Practice Guide.

SUPERVISION

- Have a system to check that control measures are in place and that they are being followed. Refer to task guidance sheet **2.3.3**.
- Employers should make sure that employees have all the means to perform the checklist given below.

PERSONAL PROTECTIVE EQUIPMENT

- Refer to task guidance sheet **2.1.15** dedicated to Personal Protective Equipment.
- Risk assessment must be carried out to determine whether existing controls are adequate. If necessary, respiratory protective equipment (with the appropriate protection factor) should be provided and worn.
- Provide storage facilities to keep personal protective equipment clean when not in use.
- Replace respiratory protective equipment at intervals recommended by its suppliers.

EMPLOYEE CHECKLIST

- | | | | |
|--|---|---|---|
| <input type="checkbox"/> Make sure that the dust extraction system is switched on and is working correctly. | <input type="checkbox"/> If you think there is a problem with your dust control equipment, ensure additional control measures are taken to reduce exposure to respirable crystalline silica while the problem persists. | <input type="checkbox"/> Clean up control rooms using vacuum or wet cleaning methods. | <input type="checkbox"/> Check and implement the measures to control the risk of bacterial growth within water sources used across site, focusing most on systems where water droplets will be generated. |
| <input type="checkbox"/> Look for signs of damage, wear or poor operation of any equipment used. If you find any problems, tell your supervisor. | <input type="checkbox"/> Clear up spills straight away. Use vacuum or wet cleaning methods. | <input type="checkbox"/> Test if control rooms are under pressure, keep doors and windows shut. | |
| | | <input type="checkbox"/> Use, maintain and store any respiratory protective equipment provided in accordance with instructions. | |

This guidance sheet is aimed at employers to help them comply with the requirements of workplace health and safety legislation, by controlling exposure to respirable crystalline silica. Specifically, this sheet provides good practice advice on dust control for drying operations.

Following the key points of this task guidance sheet will help reduce exposure.

Depending on the specific circumstances of each case, it may not be necessary to apply all of the control measures identified in this sheet in order to minimise exposure

to respirable crystalline silica. i.e. to apply appropriate protection and prevention measures. This document should also be made available to persons who may be exposed to respirable crystalline silica in the workplace, in order that they may make the best use of the control measures which are implemented.

This sheet forms part of the Good Practices Guide on silica dust prevention, which is aimed specifically at the control of personal exposure to respirable crystalline silica dust in the workplace.

GOOD PRACTICES FOR GRINDING OF MINERALS/RAW MATERIALS

This sheet gives guidance on dry grinding operations for products containing crystalline silica.

ACCESS

Restrict access to the work area to authorised personnel only.

DESIGN AND EQUIPMENT

- Ensure the grinding installation is fit for purpose and that it is well maintained.
- Use wet milling processes wherever possible, rather than dry grinding operations. This will greatly reduce airborne dust generation.
- Enclose grinding installations as much as possible and install them in well-ventilated buildings.
- Where necessary to prevent the escape of dust, grinding installations should be connected to a suitable dust extraction system, which is capable of extracting enough air to keep the relevant parts of the installation under negative pressure.
- Make arrangements for the dust-free discharge of the product from the grinding mill to other process equipment. Transfer points and subsequent plant should also be connected to a dust extraction system where necessary to prevent the escape of dust.
- Note that some parts of the system will operate at pressures above atmospheric. Provide good seals between different parts of the installation.
- Ensure all equipment is easily accessible for maintenance work.
- Provide ducts with sufficient inclination to avoid settling of product.
- Ensure minimal internal wear of ducts by using ones of adequate diameter; by selecting wear resistant materials and by avoiding sharp bends. Alumina is a good material to use to line ducts that are subject to high wear.
- Control rooms should have their own clean air supply and they should be physically separated from dusty areas. Where necessary they should be fitted with forced air filtration and maintained under positive pressure to prevent the ingress of dusty air.
- Put in place control systems to avoid overloading the grinding mills.

- Where possible, provide automated sampling, particle size analysis, telemetry and CCTV systems to reduce the amount of time operators need to spend in dusty/noisy areas.



MAINTENANCE

- Ensure equipment used in the task is maintained as advised by the supplier/installer in efficient working order and in good repair.
- Replace consumables (filters etc.) in accordance with the manufacturer's recommendations.

EXAMINATION AND TESTING

- Visually check the equipment at least once per week for signs of damage or, if it is in constant use, check it more frequently. If used infrequently, then check it before each use.
- Obtain information on the design performance of the dust suppression and/or extraction equipment from the supplier. Keep this information to compare with future test results.
- Have the extraction equipment examined and tested against its performance standard at least once each year.
- Keep records of inspections for a suitable period of time which complies with national laws (minimum five years).
- Put in place measures to control the risk of bacterial growth within water sources used across site, focusing most on systems where water droplets will be generated.

CLEANING AND HOUSEKEEPING

- Clean your workplace on a regular basis.
- **DO NOT clean up with a dry brush or using compressed air.**
- Use vacuum or wet cleaning methods.
- Develop written safe working procedures for dealing with large spillages of dusty material.

TRAINING

- Give your employees information on the health effects associated with respirable crystalline silica dust.
- Provide employees with training on: dust exposure prevention; checking controls are working and using them; when and how to use any respiratory protective equipment provided and what to do if something goes wrong. Refer to task guidance sheet **2.3.4** and part 1 of the Good Practice Guide.

SUPERVISION

- Have a system to check that control measures are in place and that they are being followed. Refer to task guidance sheet **2.3.3**.
- Employers should make sure that employees have all the means to perform the checklist given below.

PERSONAL PROTECTIVE EQUIPMENT

- Refer to task guidance sheet **2.1.15** dedicated to Personal Protective Equipment.
- Risk assessment must be carried out to determine whether existing controls are adequate. If necessary, respiratory protective equipment (with the appropriate protection factor) should be provided and worn.
- Provide storage facilities to keep personal protective equipment clean when not in use.
- Replace respiratory protective equipment at intervals recommended by its suppliers.

EMPLOYEE CHECKLIST

- | | | | |
|--|---|---|---|
| <input type="checkbox"/> Make sure the grinding installation is working properly. | <input type="checkbox"/> Dust clouds may suggest a problem with the system. Investigate them immediately. | <input type="checkbox"/> Clear up spills straight away. Use vacuum or wet cleaning methods. Dispose of spills safely. | <input type="checkbox"/> Check and implement the measures to control the risk of bacterial growth within water sources used across site, focusing most on systems where water droplets will be generated. |
| <input type="checkbox"/> Make sure all dust extraction systems are switched on and working correctly before starting work. | <input type="checkbox"/> If you think there is a problem with the plant or with your dust control equipment, ensure additional control measures are taken to reduce exposure to respirable crystalline silica while the problem persists. | <input type="checkbox"/> Clean up control rooms using vacuum or wet cleaning techniques. | |
| <input type="checkbox"/> Look for signs of damage, wear or poor operation of any equipment used. If you find any problems, tell your supervisor. | | <input type="checkbox"/> Use, maintain and store any respiratory protective equipment provided in accordance with instructions. | |

This guidance sheet is aimed at employers to help them comply with the requirements of workplace health and safety legislation, by controlling exposure to respirable crystalline silica. Specifically, this sheet provides good practice advice on dust control for grinding operations.

Following the key points of this task guidance sheet will help reduce exposure.

Depending on the specific circumstances of each case, it may not be necessary to apply all of the control measures identified in this sheet in order to minimise exposure

to respirable crystalline silica. i.e. to apply appropriate protection and prevention measures. This document should also be made available to persons who may be exposed to respirable crystalline silica in the workplace, in order that they may make the best use of the control measures which are implemented.

This sheet forms part of the Good Practices Guide on silica dust prevention, which is aimed specifically at the control of personal exposure to respirable crystalline silica dust in the workplace.

GOOD PRACTICES FOR JUMBO BAGGING

This activity covers bagging operations for big (bulk) bags (500kg-1500kg) containing crystalline silica products, particularly dry materials.

ACCESS

Restrict access to the work area to authorised personnel only.

DESIGN AND EQUIPMENT

- Ensure that bags and bag filling equipment are fit for purpose. When bagging flour products, the quality of bag stitching is crucial in preventing the emission of fine dust through the seams of the bags.
- The use of a bag with an inner plastic liner will help to reduce the emission of dust through bag seams.
- Use a bagging head in which the product passes down the centre and in which an annular ring is used for the purposes of dust extraction and for the removal of displaced air.
- The annular ring should be connected to a dust extraction unit (e.g. bag filter).
- Seal the bag collar onto the bagging head to prevent the escape of dust during bag filling. A strip of Velcro, a clamp or an inflatable bladder can be used for this purpose.
- Install bulk bagging equipment in a well-ventilated area. Outdoor installation (in an area protected from the rain) will help to reduce personal exposure to respirable crystalline silica by taking advantage of natural ventilation.
- When bagging flour products, consider the installation of a vibrator in the bagging head, to help loosen material from inside the bagging head prior to removal of each bag.
- When bagging flour products, consider the installation of a vibrating table beneath the bag in order to compact the material and improve stability during subsequent storage and transport.

MAINTENANCE

- Ensure equipment used in the task is maintained as advised by the supplier/installer in efficient working order and in good repair.
- Replace consumables (filters etc.) in accordance with the manufacturer's recommendations.



EXAMINATION AND TESTING

- Visually check the equipment at least once per week for signs of damage or, if it is in constant use, check it more frequently. If used infrequently, then check it before each use.
- Obtain information on the design performance of the dust suppression and/or extraction equipment from the supplier. Keep this information to compare with future test results.
- Have the extraction equipment examined and tested against its performance standard, at least once each year.
- Keep records of inspections for a suitable period of time which complies with national laws (minimum five years).
- Put in place measures of controlling the risk of bacterial growth within water sources used across site, focusing most on systems where water droplets will be generated.

CLEANING AND HOUSEKEEPING

- Clean your workplace on a regular basis.
- **DO NOT clean up with a dry brush or using compressed air.**
- Use vacuum or wet cleaning methods.
- Store bags in a safe place and dispose of empty bags safely.

TRAINING

- Give your employees information on the health effects associated with respirable crystalline silica dust.

- Provide employees with training on: dust exposure prevention; checking controls are working and using them; when and how to use any respiratory protective equipment provided and what to do if something goes wrong. Refer to task guidance sheet **2.3.4** and part 1 of the Good Practice Guide.

SUPERVISION

- Have a system to check that control measures are in place and that they are being followed. Refer to task guidance sheet **2.3.3**.
- Employers should make sure that employees have all the means to perform the checklist given below.

PERSONAL PROTECTIVE EQUIPMENT

- Refer to task guidance sheet **2.1.15** dedicated to Personal Protective Equipment.
- Risk assessment must be carried out to determine whether existing controls are adequate. If necessary, respiratory protective equipment (with the appropriate protection factor) should be provided and worn.
- Provide storage facilities to keep personal protective equipment clean when not in use.
- Replace respiratory protective equipment at intervals recommended by its suppliers.

EMPLOYEE CHECKLIST

- | | | | |
|--|---|---|---|
| <input type="checkbox"/> Make sure that the bagging machine is working properly. | <input type="checkbox"/> If you think there is a problem with your dust control equipment, ensure additional control measures are taken to reduce exposure to respirable crystalline silica while the problem persists. | <input type="checkbox"/> Clear up spills straight away. Use vacuum or wet cleaning methods. | <input type="checkbox"/> Check and implement the measures of controlling the risk of bacterial growth within water sources used across site, focusing most on systems where water droplets will be generated. |
| <input type="checkbox"/> Make sure the dust extraction system is switched on and that it is working correctly. | <input type="checkbox"/> Make sure that bags are free of faults, especially the loops, inlet and outlet spouts and inner liner if used. | <input type="checkbox"/> Use, maintain and store any respiratory protective equipment provided in accordance with instructions. | |
| <input type="checkbox"/> Look for signs of damage, wear or poor operation of any equipment used. If you find any problems, tell your supervisor. | | | |

This guidance sheet is aimed at employers to help them comply with the requirements of workplace health and safety legislation, by controlling exposure to respirable crystalline silica. Specifically, this sheet provides good practice advice on dust control during the jumbo bag filling.

Following the key points of this task guidance sheet will help reduce exposure.

Depending on the specific circumstances of each case, it may not be necessary to apply all of the control measures identified in this sheet in order to minimise exposure

to respirable crystalline silica. i.e. to apply appropriate protection and prevention measures. This document should also be made available to persons who may be exposed to respirable crystalline silica in the workplace, in order that they may make the best use of the control measures which are implemented.

This sheet forms part of the Good Practices Guide on silica dust prevention, which is aimed specifically at the control of personal exposure to respirable crystalline silica dust in the workplace.

GOOD PRACTICES FOR MIXING OF MATERIALS

This sheet provides guidance on the design and use of equipment used for the mixing of products containing crystalline silica, particularly dry products.

ACCESS

Restrict access to the work area to authorised personnel only.

DESIGN AND EQUIPMENT

- Ensure that mixers are fit for purpose and that they are well maintained.
- Enclose mixers as much as possible.
- Mixer lids and other access points should be sealed to prevent the escape of dust.
- All covers and access doors must be securely closed before starting the mixer.
- The mixer charging point should be enclosed and provided with local exhaust ventilation.
- Alternatively, local exhaust ventilation can be supplied at points inside the lid or rear of the mixer casing, so that there is a net influx of air through the charging point and into the mixer.
- All extraction systems should be designed so as not to draw excessive amounts of raw material from the mixer.
- When producing a dry mix, consider arrangements for dust-free discharge of mixed products. eg direct discharge to an enclosed conveyor system. Alternatively, provide local exhaust ventilation at the discharge point.
- Local exhaust ventilation systems must be connected to a suitable dust extraction unit.
- Where possible, mixer charging points should be located away from doors, windows and walkways to prevent draughts affecting the performance of local exhaust ventilation systems.
- Provide a clean air supply to the workroom to replace extracted air.

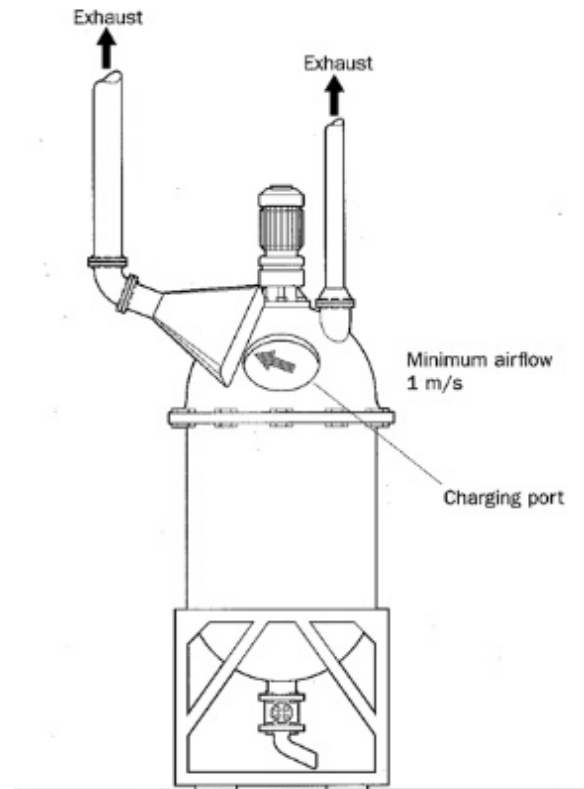

MAINTENANCE

- Ensure equipment used in the task is maintained as advised by the supplier/installer in efficient working order and in good repair.
- Replace consumables (filters etc.) in accordance with the manufacturer's recommendations.

EXAMINATION AND TESTING

- Visually check the cleaning equipment for signs of damage at least once per week or, if it is in constant use, check it more frequently. If used infrequently, then check it before each use.
- Obtain information on the design performance of dust suppression and/or extraction equipment from the supplier. Keep this information to compare with future test results.
- Keep records of inspections for a suitable period of time which complies with national laws (minimum five years).
- Put in place measures to control the risk of bacterial growth within water sources used across site, focusing most on systems where water droplets will be generated.

CLEANING AND HOUSEKEEPING

- Clean your workplace on a regular basis.
- Store containers in a safe place and dispose of empty containers safely.
- Put lids on containers immediately after use.
- Deal with spills immediately.
- **DO NOT clean up with a dry brush or using compressed air.**
- Use vacuum or wet cleaning methods.

TRAINING

- Give your employees information on the health effects associated with respirable crystalline silica dust.
- Provide employees with training on: dust exposure prevention; checking controls are working and using them; when and how to use any respiratory protective equipment provided and what to do if something goes wrong. Refer to task guidance sheet **2.3.4** and part 1 of the Good Practice Guide.

SUPERVISION

- Have a system to check that control measures are in place and that they are being followed. Refer to task guidance sheet **2.3.3**.
- Employers should make sure that employees have all the means to perform the checklist given below.

PERSONAL PROTECTIVE EQUIPMENT

- Refer to task guidance sheet **2.1.15** dedicated to Personal Protective Equipment.
- Risk assessment must be carried out to determine whether existing controls are adequate. If necessary, respiratory protective equipment (with the appropriate protection factor) should be provided and worn.
- Provide storage facilities to keep personal protective equipment clean when not in use.
- Replace respiratory protective equipment at intervals recommended by its suppliers.

EMPLOYEE CHECKLIST

- | | | | |
|--|--|---|---|
| <input type="checkbox"/> Make sure the work area is well ventilated and that any dust extraction system is switched on and is working correctly. | <input type="checkbox"/> Look for signs of damage, wear or poor operation of any equipment used. If you find any problems, tell your supervisor. | <input type="checkbox"/> Use, maintain and store any respiratory protective equipment provided in accordance with instructions. | <input type="checkbox"/> Check and implement the measures of controlling the risk of bacterial growth within water sources used across site, focusing most on systems where water droplets will be generated. |
| <input type="checkbox"/> Clear up spills straight away. Use vacuum or wet cleaning methods. Dispose of spills immediately. | <input type="checkbox"/> If you think there is a problem with your dust control equipment, ensure additional control measures are taken to reduce exposure to respirable crystalline silica dust while the problem persists. | | |

This guidance sheet is aimed at employers to help them comply with the requirements of workplace health and safety legislation, by controlling exposure to respirable crystalline silica. Specifically, this sheet provides advice on dust control when mixing materials containing crystalline silica dust.

Following the key points of this task guidance sheet will help reduce exposure.

Depending on the specific circumstances of each case, it may not be necessary to apply all of the control measures identified in this sheet in order to minimise exposure

to respirable crystalline silica. i.e. to apply appropriate protection and prevention measures. This document should also be made available to persons who may be exposed to respirable crystalline silica in the workplace, in order that they may make the best use of the control measures which are implemented.

This sheet forms part of the Good Practices Guide on silica dust prevention, which is aimed specifically at the control of personal exposure to respirable crystalline silica dust in the workplace.

GOOD PRACTICES FOR USING WATER/ ADDITIVES ON THE ROADS OR OPEN SURFACES TO REDUCE DUST LEVELS

This sheet provides advice on the use of water, additives or a combination of both to reduce dust levels on the roads or in open surfaces in a quarry. This activity relates to the use of water sprays, atomized water mists or additives (e.g. calcium chloride, etc.) to suppress the generation and lower the concentration of airborne crystalline silica dusts on the roads or in open surfaces. Another option is to use lime or cement to stabilise the roads when needed.

ACCESS

Restrict access to the work area to authorised personnel only.

DESIGN AND EQUIPMENT

- For paved roads, consider using a road sweeper.
- If possible, use water fed systems (static or mobile), or trucks sprinkling water for both paved and unpaved roads or working surfaces in the quarry.
- In circumstances where there will be no adverse effects on the environment, process conditions, product quality or health and safety, apply water mists in work areas where airborne crystalline silica may be generated by material and product handling.
- When using additives, a previous evaluation of their effects should be carried out.
- Ensure electrical systems have adequate protection when used with water suppression, spraying or misting.
- Take precautions to ensure the control of legionella and other biological agents in water storage and delivery systems.
- Take precautions to ensure that wastewater and sludges are disposed according to local legislation.
- When possible, it is recommended to use recycled water.
- Consider the use of automatic regulation based on weather conditions (e.g. wind speed, rainfall, etc.). Alternatively, establish a procedure to manage the use of the water system.
- Ensure that the system is designed with an appropriate relationship between the size of the dust and the size of the water drop particles.



MAINTENANCE

- Ensure water dust suppression equipment used in the task is maintained as advised by the supplier/installer in efficient working order and good repair.
- Replace consumables in accordance with the manufacturer's recommendations.

EXAMINATION AND TESTING

- Visually check all equipment for signs of damage at least once per week or, if it is in constant use, check it more frequently. If used infrequently, then check it before each use.
- Obtain information on the design performance of dust suppression equipment and of the additives from the supplier (if possible). Keep this information to compare with future test results.
- Keep records of inspections for a suitable period of time which complies with national laws (minimum five years).
- Put in place measures to control the risk of bacterial growth within water sources used across site, focusing most on systems where water droplets will be generated.

CLEANING AND HOUSEKEEPING

- Clean water dust suppression equipment as instructed by the manufacturer/supplier.
- **Avoid accumulation of slurries/sludges.**
- Ensure spills are cleaned up immediately, and provide adequate spill control equipment.
- **Avoid the dispersion of the collected dust of slurries/sludges.**

TRAINING

- Give your employees information on the health effects associated with respirable crystalline silica dust.
- Provide employees with training on: dust exposure prevention; checking controls are working and using them; when and how to use any respiratory protective equipment provided and what to do if something goes wrong. Refer to task guidance sheet **2.3.4** (Training) and part 1 of the Good Practice Guide.

SUPERVISION

- Have a system to check that control measures are in place and that they are being followed. Refer to task guidance sheet **2.3.3** (Supervision).
- Employers should make sure that employees have all the means to perform the checklist given below.

PERSONAL PROTECTIVE EQUIPMENT

- Refer to task guidance sheet **2.1.15** dedicated to Personal Protective Equipment.
- Risk assessment must be carried out to determine whether existing controls are adequate. If necessary, respiratory protective equipment (with the appropriate protection factor) should be provided and worn.
- Provide storage facilities to keep personal protective equipment clean when not in use.
- Replace respiratory protective equipment at intervals recommended by its suppliers.

EMPLOYEE CHECKLIST

- | | | | |
|---|---|--|---|
| <input type="checkbox"/> Make sure that water dust suppression equipment is working properly. | <input type="checkbox"/> Protect water supplies against freezing. | <input type="checkbox"/> Clean dust suppression equipment regularly and after use. | <input type="checkbox"/> Check and implement the measures of controlling the risk of bacterial growth within water sources used across site, focusing most on systems where water droplets will be generated. |
| <input type="checkbox"/> Ensure water supplies are adequate with an uninterrupted supply during use for dust suppression. | <input type="checkbox"/> Look for signs of damage or malfunction, and if you find any tell your supervisor immediately. | <input type="checkbox"/> Keep personal protective equipment clean and properly stored. | |
| | <input type="checkbox"/> Clean up spills immediately. | | |

This guidance sheet is aimed at employers to help them comply with the requirements of workplace health and safety legislation, by controlling exposure to respirable crystalline silica.

Following the key points of this task guidance sheet will help reduce exposure.

Depending on the specific circumstances of each case, it may not be necessary to apply all of the control measures identified in this sheet in order to minimise exposure

to respirable crystalline silica. i.e. to apply appropriate protection and prevention measures. This document should also be made available to persons who may be exposed to respirable crystalline silica in the workplace, in order that they may make the best use of the control measures which are implemented.

This sheet forms part of the Good Practices Guide on silica dust prevention, which is aimed specifically at the control of personal exposure to respirable crystalline silica in the workplace.

GOOD PRACTICES FOR SCREENING

This activity covers the dry screening of products containing crystalline silica.

ACCESS

Restrict access to the work area to authorised personnel only.

DESIGN AND EQUIPMENT

- Ensure the dry screening equipment is fit for purpose and that it is well maintained.
- Screens should be enclosed as far as possible.
- Screen enclosures should be connected to a suitable dust extraction system (e.g. bag filter/cyclone/scrubber).
- Flexible hoses should be used to connect screen enclosures to the extraction system. These hoses must be durable (due to the constant motion of the screen) and must be properly sealed onto the screen enclosure. Any gaps will reduce performance of the extraction system and result in dust emissions into the workplace air.
- Transfer points, between screens and conveyors, should be sealed as far as possible and served with dust extraction systems.
- Ensure that screening equipment is designed and installed so as to be easily accessible for maintenance work.
- Control cabins should have their own clean air supply. Where necessary, they should be fitted with forced air filtration and maintained under positive pressure to prevent the ingress of dusty air.
- Screens should be equipped with lifting aids for use when lifting and positioning new screens.

MAINTENANCE

- Ensure equipment used in the task is maintained as advised by the supplier/installer in efficient working order and in good repair.
- Replace consumables (filters etc.) in accordance with the manufacturer's recommendations.



EXAMINATION AND TESTING

- Visually check the equipment at least once per week for signs of damage or, if it is in constant use, check it more frequently. If used infrequently, then check it before each use.
- Obtain information on the design performance of the dust suppression and/or extraction equipment from the supplier. Keep this information to compare with future test results.
- Keep records of inspections for a suitable period of time which complies with national laws (minimum five years).
- Check on a regular basis that extraction ducting and flexible hoses are not obstructed.
- Put in place measures to control the risk of bacterial growth within water sources used across site, focusing most on systems where water droplets will be generated.

CLEANING AND HOUSEKEEPING

- Clean your workplace on a regular basis.
- **DO NOT clean up with a dry brush or using compressed air.**
- Use vacuum or wet cleaning methods.

TRAINING

- Give your employees information on the health effects associated with respirable crystalline silica dust.
- Provide employees with training on: dust exposure prevention; checking controls are working and using them; when and how to use any respiratory protective equipment provided and what to do if something goes wrong. Refer to task guidance sheet **2.3.4** and part 1 of the Good Practice Guide.

SUPERVISION

- Have a system to check that control measures are in place and that they are being followed. Refer to task guidance sheet **2.3.3**.
- Employers should make sure that employees have all the means to perform the checklist given below.

PERSONAL PROTECTIVE EQUIPMENT

- Refer to task guidance sheet **2.1.15** dedicated to Personal Protective Equipment.
- Risk assessment must be carried out to determine whether existing controls are adequate. If necessary, respiratory protective equipment (with the appropriate protection factor) should be provided and worn.
- Provide storage facilities to keep personal protective equipment clean when not in use.
- Replace respiratory protective equipment at intervals recommended by its suppliers.

EMPLOYEE CHECKLIST

- | | | | |
|--|---|---|---|
| <input type="checkbox"/> Make sure the screening equipment is working properly. | <input type="checkbox"/> Look for signs of damage, wear or poor operation of any equipment used. If you find any problems, tell your supervisor. | <input type="checkbox"/> Use handling aids when available. | <input type="checkbox"/> Use, maintain and store any respiratory protective equipment provided in accordance with instructions. |
| <input type="checkbox"/> Make sure the dust extraction system is switched on and is working correctly. | <input type="checkbox"/> If you think there is a problem with your dust control equipment, ensure additional control measures are taken to reduce exposure to respirable crystalline silica while the problem persists. | <input type="checkbox"/> Clear up spills straight away. Use vacuum or wet cleaning methods. | <input type="checkbox"/> Check and implement the measures of controlling the risk of bacterial growth within water sources used across site, focusing most on systems where water droplets will be generated. |
| <input type="checkbox"/> Check that screen enclosures are securely connected to the extraction system and that the flexible hoses are in good condition. | | <input type="checkbox"/> Clean up control rooms using vacuum or wet cleaning methods. | |

This guidance sheet is aimed at employers to help them comply with the requirements of workplace health and safety legislation, by controlling exposure to respirable crystalline silica. Specifically, this sheet provides advice on dust control for dry screening operations.

Following the key points of this task guidance sheet will help reduce exposure.

Depending on the specific circumstances of each case, it may not be necessary to apply all of the control measures identified in this sheet in order to minimise exposure

to respirable crystalline silica. i.e. to apply appropriate protection and prevention measures. This document should also be made available to persons who may be exposed to respirable crystalline silica in the workplace, in order that they may make the best use of the control measures which are implemented.

This sheet forms part of the Good Practices Guide on silica dust prevention, which is aimed specifically at the control of personal exposure to respirable crystalline silica dust in the workplace.

GOOD PRACTICES FOR SMALL BAG FILLING – COARSE PRODUCTS

This activity covers bagging operations for small bags (15kg-50kg) with dry products containing crystalline silica. This sheet is only relevant to products in which the grains have not been ground down to flour, i.e. sand sized or coarser. The bagging of flours is covered in sheet **2.2.30b**.

ACCESS

Restrict access to the work area to authorised personnel only.

DESIGN AND EQUIPMENT

- Ensure that bags and bag filling equipment are fit for purpose. The quality of the bags is crucial to preventing leakage of dust through the bag seams.
- Use bagging heads in which the product passes down the centre and in which an outer, annular ring is used for the purposes of dust extraction and for the removal of displaced air. The outer, annular ring should be connected to a dust extraction unit (e.g. bag filter).
- Ensure that bags are effectively clamped/sealed onto the bagging head during bag filling to prevent the escape of dust.
- Position the bagging head inside a dust extraction hood which is enclosed as much as possible.
- The dust extraction system serving the hood must have sufficient capture velocity to prevent the escape of dust emitted through the bag seams and dust discharged from the bagging head when the bag is removed. Refer to task guidance sheet **2.1.13**.
- Bags must be sealed shut as soon as they are removed from the bagging head. Bags with self-sealing valves are available or, alternatively, bag stitching or heat sealing techniques may be used.
- Consider mechanical/pneumatic assistance with bag handling.
- In automated bagging systems, the use of a carousel system enables many bags to be filled simultaneously at a very slow rate using a screw feed. When bags are filled slowly, less dust is emitted.



MAINTENANCE

- Ensure equipment used in the task is maintained as advised by the supplier/installer in efficient working order and in good repair.
- Replace consumables (filters etc.) in accordance with the manufacturer's recommendations.

EXAMINATION AND TESTING

- Visually check the equipment at least once per week for signs of damage or, if it is in constant use, check it more frequently. If used infrequently, then check it before each use.
- Obtain information on the design performance of the dust suppression and/or extraction equipment from the supplier. Keep this information to compare with future test results.
- Keep records of inspections for a suitable period of time which complies with national laws (minimum five years).
- Put in place measures to control the risk of bacterial growth within water sources used across site, focusing most on systems where water droplets will be generated.

CLEANING AND HOUSEKEEPING

- Clean your workplace on a regular basis.
- **DO NOT clean up with a dry brush or using compressed air.**
- Use vacuum or wet cleaning methods.
- Store bags in a safe place and dispose of empty bags safely.

TRAINING

- Give your employees information on the health effects associated with respirable crystalline silica dust.
- Provide employees with training on: dust exposure prevention; checking controls are working and using them; when and how to use any respiratory protective equipment provided and what to do if something goes wrong. Refer to task guidance sheet **2.3.4** and part 1 of the Good Practice Guide.

SUPERVISION

- Have a system to check that control measures are in place and that they are being followed. Refer to task guidance sheet **2.3.3**.
- Employers should make sure that employees have all the means to perform the checklist given below.

PERSONAL PROTECTIVE EQUIPMENT

- Refer to task guidance sheet **2.1.15** dedicated to Personal Protective Equipment.
- Risk assessment must be carried out to determine whether existing controls are adequate. If necessary, respiratory protective equipment (with the appropriate protection factor) should be provided and worn.
- Provide storage facilities to keep personal protective equipment clean when not in use.
- Replace respiratory protective equipment at intervals recommended by its suppliers.

EMPLOYEE CHECKLIST

- | | | | |
|---|---|--|---|
| <input type="checkbox"/> Make sure that the bagging machine is working properly. | <input type="checkbox"/> Look for signs of damage, wear or poor operation of any equipment used. If you find any problems, tell your supervisor. | <input type="checkbox"/> Even if it is not normally necessary for you to wear a dust mask, it may be necessary for you to wear one temporarily in the event of a spillage or if other control measures fail. | equipment provided in accordance with instructions. |
| <input type="checkbox"/> Make sure that bags are free from defects, especially as regards valve construction. | <input type="checkbox"/> If you think there is a problem with your dust control equipment, ensure additional control measures are taken to reduce exposure to respirable crystalline silica while the problem persists. | <input type="checkbox"/> Clear up spills straight away. Use vacuum or wet cleaning methods. | <input type="checkbox"/> Use handling aids when available. |
| <input type="checkbox"/> Make sure that the dust extraction system is switched on and is working correctly. | | <input type="checkbox"/> Use, maintain and store any respiratory protective | <input type="checkbox"/> Check and implement the measures of controlling the risk of bacterial growth within water sources used across site, focusing most on systems where water droplets will be generated. |

This guidance sheet is aimed at employers to help them comply with the requirements of workplace health and safety legislation, by controlling exposure to respirable crystalline silica. Specifically, this sheet provides advice on dust control during the filling of small bags with coarse products.

Following the key points of this task guidance sheet will help reduce exposure.

Depending on the specific circumstances of each case, it may not be necessary to apply all of the control measures identified in this sheet in order to minimise exposure

to respirable crystalline silica. i.e. to apply appropriate protection and prevention measures. This document should also be made available to persons who may be exposed to respirable crystalline silica in the workplace, in order that they may make the best use of the control measures which are implemented.

This sheet forms part of the Good Practices Guide on silica dust prevention, which is aimed specifically at the control of personal exposure to respirable crystalline silica in the workplace.

GOOD PRACTICES FOR SMALL BAG FILLING – FLOURS/FINES

This activity covers bagging operations for small bags (5kg-50kg) with dry products containing crystalline silica.

This sheet is only relevant to the non-automated bagging of flours (products in which the grains have been ground down to a fine powder or which are naturally fine, e.g. clay powder). The bagging of coarse products is covered by guidance sheet **2.2.30a**.

ACCESS

Restrict access to the work area to authorised personnel only.

DESIGN AND EQUIPMENT

- Ensure that bags and bag filling equipment are fit for purpose. The quality of the bags is crucial to preventing leakage of dust through the bag seams.
- Consideration should be given to screw bag filling, rather than combined rotary impellor/air packing. The screw filling method will reduce the problem of having to remove entrained dusty air from the bags.
- Flour products should be conditioned prior to bag filling. By leaving the flour to settle inside the storage silo, the material will become compacted thus removing entrained air. Conditioning in this way will ensure a more consistent bulk density, facilitating better control of the bagging process.
- When designing hoppers for effective product conditioning, consideration will need to be given to height constraints.
- Ensure that bags are effectively clamped/sealed onto the bagging head during bag filling to prevent the escape of dust.
- Position the bagging head inside a dust extraction hood which is enclosed as much as possible. Refer to task guidance sheet **2.1.13**.
- The dust extraction system serving the hood must have sufficient capture velocity to prevent the escape of any dust emitted through the bag seams and dust discharged from the bagging head when the bag is removed.



- Bags must be sealed shut as soon as they are removed from the bagging head. Bags with self-sealing valves are available or, alternatively, bag stitching techniques may be used.
- Consider mechanical/pneumatic assistance with bag handling.
- When bagging silica flour products, consideration should be given to full or partial automation of the process in order to prevent personal exposure to respirable crystalline silica dust.
- In automated bagging systems, the use of a carousel system enables many bags to be filled simultaneously at a very slow rate using a screw feed. When bags are filled slowly, less dust is emitted.

MAINTENANCE

- Ensure equipment used in the task is maintained as advised by the supplier/installer in efficient working order and in good repair.
- Replace consumables (filters etc.) in accordance with the manufacturer's recommendations.

EXAMINATION AND TESTING

- Visually check the equipment at least once per week for signs of damage or, if it is in constant use, check it more frequently. If used infrequently, then check it before each use.
- Obtain information on the design performance of the dust suppression and/or extraction equipment from the supplier. Keep this information to compare with future test results.
- Keep records of inspections for a suitable period of time which complies with national laws (minimum five years).
- Put in place measures to control the risk of bacterial growth within water sources used across site, focusing most on systems where water droplets will be generated.

CLEANING AND HOUSEKEEPING

- Clean your workplace on a regular basis.
- **DO NOT clean up with a dry brush or using compressed air.**
- Use vacuum or wet cleaning methods.
- Store bags in a safe place and dispose of empty bags safely.

TRAINING

- Give your employees information on the health effects associated with respirable crystalline silica dust.
- Provide employees with training on: dust exposure prevention; checking controls are working and using them; when and how to use any respiratory protective equipment provided and what to do if something goes wrong. Refer to task guidance sheet **2.3.4** and part 1 of the Good Practice Guide.

SUPERVISION

- Have a system to check that control measures are in place and that they are being followed. Refer to task guidance sheet **2.3.3**.
- Employers should make sure that employees have all the means to perform the checklist given below.

PERSONAL PROTECTIVE EQUIPMENT

- Refer to task guidance sheet **2.1.15** dedicated to Personal Protective Equipment.
- Risk assessment must be carried out to determine whether existing controls are adequate. If necessary, respiratory protective equipment (with the appropriate protection factor) should be provided and worn.
- Provide storage facilities to keep personal protective equipment clean when not in use.
- Replace respiratory protective equipment at intervals recommended by its suppliers.

EMPLOYEE CHECKLIST

- | | | | |
|---|---|--|---|
| <input type="checkbox"/> Make sure that the bagging machine is working properly. | <input type="checkbox"/> Look for signs of damage, wear or poor operation of any equipment used. If you find any problems, tell your supervisor. | <input type="checkbox"/> Even if it is not normally necessary for you to wear a dust mask, it may be necessary for you to wear one temporarily in the event of a spillage or if other control measures fail. | <input type="checkbox"/> Use, maintain and store any respiratory protective equipment provided in accordance with instructions. |
| <input type="checkbox"/> Make sure that bags are free from defects, especially as regards valve construction. | <input type="checkbox"/> If you think there is a problem with your dust control equipment, ensure additional control measures are taken to reduce exposure to respirable crystalline silica while the problem persists. | <input type="checkbox"/> Clear up spills straight away. Use vacuum or wet cleaning methods. | <input type="checkbox"/> Use handling aids when available. |
| <input type="checkbox"/> Make sure that the dust extraction system is switched on and is working correctly. | | | <input type="checkbox"/> Check and implement the measures of controlling the risk of bacterial growth within water sources used across site, focusing most on systems where water droplets will be generated. |

This guidance sheet is aimed at employers to help them comply with the requirements of workplace health and safety legislation, by controlling exposure to respirable crystalline silica. Specifically, this sheet provides advice on dust control during the filling of small bags with flour products.

Following the key points of this task guidance sheet will help reduce exposure.

Depending on the specific circumstances of each case, it may not be necessary to apply all of the control measures identified in this sheet in order to minimise exposure

to respirable crystalline silica. i.e. to apply appropriate protection and prevention measures. This document should also be made available to persons who may be exposed to respirable crystalline silica in the workplace, in order that they may make the best use of the control measures which are implemented.

This sheet forms part of the Good Practices Guide on silica dust prevention, which is aimed specifically at the control of personal exposure to respirable crystalline silica in the workplace.

GOOD PRACTICES FOR AUTOMATED SMALL BAG FILLING

This activity covers bagging operations for small bags (2.5kg-50kg) with dry products containing crystalline silica. This sheet is only relevant to the automated bagging of flours, fines and powder. For automated bagging, “form fill seal” technology allows for effective control of airborne dust generation when bagging powders. The bagging of coarse products is covered by sheet **2.2.30a**, and the non-automated bagging of flours, fines and powder is covered by **2.2.30b**.

ACCESS

Restrict access to the work area to authorised personnel only.

DESIGN AND EQUIPMENT

- Ensure that bags and bag filling equipment are fit for purpose. The quality of the bags is crucial to preventing leakage of dust. It is strongly recommended to use automated bag feeding machines so that human operation is restricted to monitoring, unblocking, maintenance & repair. Placing onto pallets may be automated using a robot palletiser.
- Use long roll of plastic film to produce the bags. The plastic film is formed into a continuous, sealed sock, into which the silica containing material is poured. As such, the process is largely enclosed. The top and bottom of each bag is sealed using a heat sealer.
- Use local exhaust ventilation at all points where airborne dust may be generated.
- Release entrained air in order to allow the bags to be stacked onto pallets. This may be done by lightly compressing the bags after filling. For coarse materials (e.g. sand sized), entrained air is released through micro-perforations in the bags. For fine/flour materials, the use of micro-perforations may not be suitable. In this case, the air may be released through a specially designed seal on each bag, with local exhaust ventilation.
- Get advice from a specialist provider of bagging machinery in order to ensure the machinery, including the local exhaust ventilation system, is designed correctly for the type of material.
- Use bagging equipment designed & manufactured by specialised companies, conforming to the European legislation for Environmental protection, Safety & Health.
- Ensure that bags are effectively attached onto the bagging head during bag filling to prevent the escape of dust.

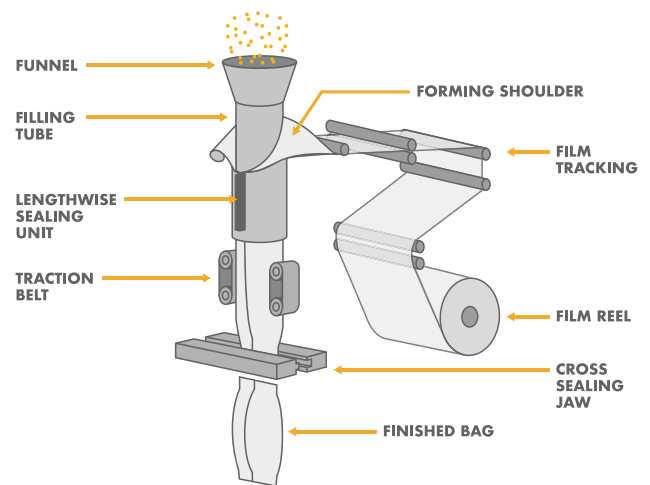

- Provide properly designed de-dusting systems as integral parts of the bagging machines.
- Bags must be sealed shut as soon as they are removed from the bagging head. Bags with self-sealing valves are available or, alternatively, bag stitching techniques, heat and ultrasonic sealing may be used.
- Consider mechanical/pneumatic assistance with bag handling.
- When bagging silica powder products, consideration should be given to full or partial automation of the process in order to prevent personal exposure to respirable crystalline silica dust.
- In automated bagging systems, the use of a carousel system enables many bags to be filled simultaneously. When bags are filled slowly, less dust is emitted.

MAINTENANCE

- Ensure equipment used in the task is maintained as advised by the supplier/installer in efficient working order and in good repair.
- Replace consumables (filters etc.) in accordance with the manufacturer’s recommendations.

EXAMINATION AND TESTING

- Visually check the equipment at least once per week for signs of damage or, if it is in constant use, check it more frequently. If used infrequently, then check it before each use.
- Obtain information on the design performance of the dust suppression and/or extraction equipment from the supplier. Keep this information to compare with future test results.
- Keep records of inspections for a suitable period of time which complies with national laws (minimum five years).
- Put in place measures to control the risk of bacterial growth within water sources used across site, focusing most on systems where water droplets will be generated.

CLEANING AND HOUSEKEEPING

- Clean your workplace on a regular basis.
- **DO NOT clean up with a dry brush or using compressed air.**
- Use vacuum or wet cleaning methods.
- Store bags in a safe place and dispose of empty bags safely.

TRAINING

- Give your employees information on the health effects associated with respirable crystalline silica dust.

- Provide employees with training on: dust exposure prevention; checking controls are working and using them; when and how to use any respiratory protective equipment provided and what to do if something goes wrong. Refer to task guidance sheet **2.3.4** and part 1 of the Good Practice Guide.

SUPERVISION

- Have a system to check that control measures are in place and that they are being followed. Refer to task guidance sheet **2.3.3** dedicated to Supervision.
- Employers should make sure that employees have all the means to perform the checklist given below.

PERSONAL PROTECTIVE EQUIPMENT

- Refer to task guidance sheet **2.1.15** dedicated to Personal Protective Equipment.
- Risk assessment must be carried out to determine whether existing controls are adequate. If necessary, respiratory protective equipment (with the appropriate protection factor) should be provided and worn.
- Provide storage facilities to keep personal protective equipment clean when not in use.
- Replace respiratory protective equipment at intervals recommended by its suppliers.

EMPLOYEE CHECKLIST

- | | | | |
|---|---|--|---|
| <input type="checkbox"/> Make sure that the bagging machine is working properly. | <input type="checkbox"/> Look for signs of damage, wear or poor operation of any equipment used. | <input type="checkbox"/> Even if it is not normally necessary for you to wear a dust mask, it may be necessary for you to wear one temporarily in the event of a spillage or if other control measures fail. | equipment provided in accordance with instructions. |
| <input type="checkbox"/> Make sure that bags are free from defects, especially as regards valve construction. | <input type="checkbox"/> If you find any problems, tell your supervisor. If you think there is a problem with your dust control equipment, ensure additional control measures are taken to reduce exposure to respirable crystalline silica while the problem persists. | <input type="checkbox"/> Clear up spills straight away. Use vacuum or wet cleaning methods. | <input type="checkbox"/> Use handling aids when available. |
| <input type="checkbox"/> Make sure that the dust extraction system is switched on and is working correctly. | | <input type="checkbox"/> Use, maintain and store any respiratory protective | <input type="checkbox"/> Check and implement the measures of controlling the risk of bacterial growth within water sources used across site, focusing most on systems where water droplets will be generated. |

This guidance sheet is aimed at employers to help them comply with the requirements of workplace health and safety legislation, by controlling exposure to respirable crystalline silica. Specifically, this sheet provides advice on dust control during the filling of small bags with flour, fine and powder products.

Following the key points of this task guidance sheet will help reduce exposure.

Depending on the specific circumstances of each case, it may not be necessary to apply all of the control measures identified in this sheet in order to minimise exposure

to respirable crystalline silica. i.e. to apply appropriate protection and prevention measures. This document should also be made available to persons who may be exposed to respirable crystalline silica in the workplace, in order that they may make the best use of the control measures which are implemented.

This sheet forms part of the Good Practices Guide on silica dust prevention, which is aimed specifically at the control of personal exposure to respirable crystalline silica in the workplace.

GOOD PRACTICES FOR TRANSPORT SYSTEMS FOR FINE DRY SILICA PRODUCTS

This activity relates to the design of the transport systems for fine dry silica products.

ACCESS

Restrict access to the work area to authorised personnel only.

DESIGN AND EQUIPMENT

- It is preferable to use enclosed handling systems when transporting silica flour.
- **Pneumatic systems** are appropriate for both horizontal and vertical transport of silica flour.
- For horizontal transport in **pneumatic systems**, pipes should be angled downwards where possible to prevent flour settling in the pipes and causing a blockage in the event system pressure is lost.
- The pipe work in **pneumatic systems** should be designed to minimise unnecessary obstacles and to minimise sharp bends. Pipe connections should be properly sealed.
- For **air slides**, the fluidising air will be drawn away by the dust extraction system. For this reason, air slides cannot be used if the product is too fine. If the surface area is more than 10,000 cm²/g, use screw conveyors. More than one de-dusting connection may be required on long lengths in order to correctly balance airflows.
- **Air slides** should be inclined slightly in order to assist the horizontal transport of silica flour. The quality of the cloth used in air slides should be selected to avoid excessive pressure loss for the fan, whilst also preventing silica flour from falling through the cloth and causing it to become blocked.
- For **screw conveyors**, the screw must be enclosed. Specialist design is required due to the abrasive properties of silica flour (contact an experienced supplier).
- **Screw conveyors** may need to be equipped with dust extraction systems unless they are connected to equipment that already operates under negative pressure. Refer to task guidance sheet **2.1.13**.
- **Conveyor belts are not suitable for the transportation of loose silica flour.** However, they may be used for the transport of other, coarser, materials and in machinery that handles bags of silica flour. Conveyors handling bags of silica flour, or other dusty materials, should be enclosed and equipped with dust extraction.
- **Elevators** are suitable for vertical transport, provided they are fully enclosed. Dust extraction systems may be required unless elevators are connected to equipment that already operates under negative pressure.
- It may be necessary to apply fluidising air at the base of **silos** holding silica flour. Such systems should be designed so that the fluidising air is only applied at times when it is necessary to make the silica flour flow out of the silo. Fluidising air should not be left switched on permanently in situations where the air could migrate and cause silica flour to be emitted under pressure from elsewhere in the system.



GUIDANCE FOR EMPLOYERS ON CONTROLLING EXPOSURE TO RCS IN THE WORKPLACE

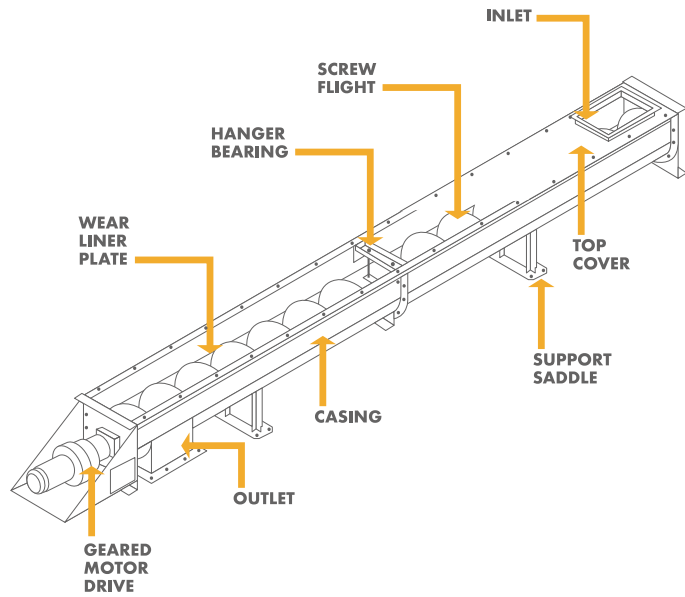

MAINTENANCE

- Ensure equipment used in the task is maintained as advised by the supplier/installer in efficient working order and in good repair.
- Replace consumables (filters etc.) in accordance with the manufacturer’s recommendations.

EXAMINATION AND TESTING

- Visually check the equipment at least once per week for signs of damage or, if it is in constant use, check it more frequently. If used infrequently, then check it before each use.
- Obtain information on the design performance of the dust suppression and/or extraction equipment from the supplier. Keep this information to compare with future test results.
- Keep records of inspections for a suitable period of time which complies with national laws (minimum five years).
- Put in place measures to control the risk of bacterial growth within water sources used across site, focusing most on systems where water droplets will be generated.

CLEANING AND HOUSEKEEPING

- Clean your workplace on a regular basis.
- **DO NOT clean up with a dry brush or using compressed air.**
- Use vacuum or wet cleaning methods.

TRAINING

- Give your employees information on the health effects associated with respirable crystalline silica dust.
- Provide employees with training on: dust exposure prevention; checking controls are working and using them; when and how to use any respiratory protective equipment provided and what to do if something goes wrong. Refer to task guidance sheet **2.3.4** and part 1 of the Good Practice Guide.

SUPERVISION

- Have a system to check that control measures are in place and that they are being followed. Refer to task guidance sheet **2.3.3**.
- Employers should make sure that employees have all the means to perform the checklist given on the following page.

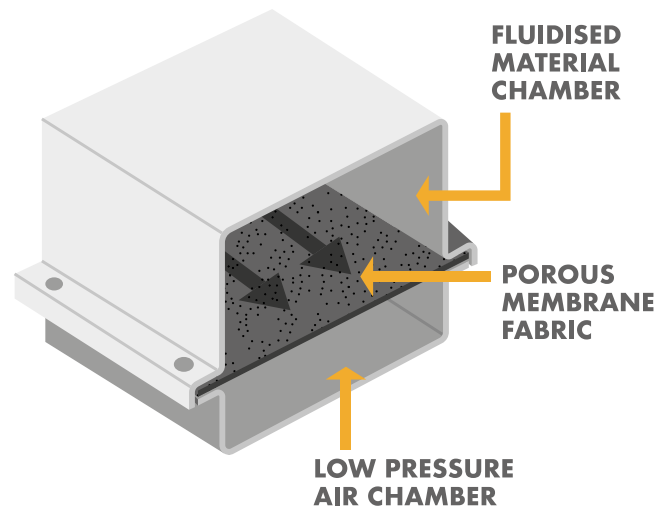

PERSONAL PROTECTIVE EQUIPMENT

- Refer to task guidance sheet **2.1.15** dedicated to Personal Protective Equipment.
- Provide pictograms on doors to indicate areas where respiratory protective equipment must be worn.
- Provide storage facilities to keep personal protective equipment clean when not in use.
- Provide enough places where Personal protective equipment can be found (e.g. box with disposable dust masks). Indicate those places with pictograms.

EMPLOYEE CHECKLIST

- | | | | |
|--|--|---|---|
| <input type="checkbox"/> Look for signs of damage or wear of building parts and of your work equipment. If you find any problems, tell your supervisor. | <input type="checkbox"/> If you think there is a problem with your dust control equipment, ensure additional control measures are taken to reduce exposure to respirable crystalline silica dust while the problem persists. | <input type="checkbox"/> Clean up control cabins using vacuum or wet cleaning methods. | <input type="checkbox"/> Check and implement the measures of controlling the risk of bacterial growth within water sources used across site, focusing most on systems where water droplets will be generated. |
| <input type="checkbox"/> Problems with silica flour transportation systems may be indicated by emissions of dust into the workplace air and by the appearance of piles of silica flour on floors and surfaces. Report any of these to your supervisor. | <input type="checkbox"/> Clear up spills straight away. Use vacuum cleaning or wet mopping. Dispose of spills safely. | <input type="checkbox"/> Use, maintain and store any respiratory protective equipment provided in accordance with instructions. | |

This guidance sheet is aimed at employers to help them comply with the requirements of workplace health and safety legislation, by controlling exposure to respirable crystalline silica. Specifically, this sheet provides advice on the design of transport systems for silica flour products.

Following the key points of this task guidance sheet will help reduce exposure.

Depending on the specific circumstances of each case, it may not be necessary to apply all of the control measures identified in this sheet in order to minimise exposure

to respirable crystalline silica. i.e. to apply appropriate protection and prevention measures. This document should also be made available to persons who may be exposed to respirable crystalline silica in the workplace, in order that they may make the best use of the control measures which are implemented.

This sheet forms part of the Good Practices Guide on silica dust prevention, which is aimed specifically at the control of personal exposure to respirable crystalline silica dust in the workplace.

GOOD PRACTICES FOR USE OF A DRILLING RIG

This activity covers drilling operations into rocks or strata containing crystalline silica. Drilling may be carried out for exploratory or reserve assessment purposes, or as part of the minerals extraction process.

ACCESS

Restrict access to the work area to authorised personnel only.

DESIGN AND EQUIPMENT

- Dust control can be achieved using water fed into the compressed air supply, thereby suppressing the dust. Additives may need to be used for lubrication.
- Ensure that water supplies are adequate and that they are maintained. Take extra precautions during cold weather to protect against freezing.
- The use of a foaming agent for dust suppression is also possible.
- Alternatively, dust control may be achieved by extraction of the dry dust using local exhaust ventilation, connected to a suitable dust extraction system (e.g. a bag filter/cyclone), or by using spray mist dust suppression. Refer to task guidance sheet **2.1.13**.
- Drilling equipment with an integral control cabin or remote control facility with closed doors and windows may be used to isolate personnel from dust sources.
- Control cabins can be fitted with forced air filtration or full air conditioning.

MAINTENANCE

- Ensure equipment used in the task is maintained as advised by the supplier/installer in efficient working order and in good repair.
- Replace consumables (filters etc.) in accordance with the manufacturer's recommendations.
- It is preferable that all maintenance functions that could be done in a workshop be done in a workshop.



GUIDANCE FOR EMPLOYERS ON CONTROLLING EXPOSURE TO RCS IN THE WORKPLACE

EXAMINATION AND TESTING

- Visually check the equipment at least once per week for signs of damage or, if it is in constant use, check it more frequently. If used infrequently, then check it before each use.
- Obtain information on the design performance of the dust suppression and/or extraction equipment from the supplier. Keep this information to compare with future test results.
- Keep records of inspections for a suitable period of time which complies with national laws (minimum five years).
- Put in place measures to control the risk of bacterial growth within water sources used across site, focusing most on systems where water droplets will be generated.

CLEANING AND HOUSEKEEPING

- Clean your workplace on a regular basis.
- **DO NOT clean up with a dry brush or using compressed air.**
- Use vacuum or wet cleaning methods.

TRAINING

- Give your employees information on the health effects associated with respirable crystalline silica dust.

- Provide employees with training on: dust exposure prevention; checking controls are working and using them; when and how to use any respiratory protective equipment provided and what to do if something goes wrong. Refer to task guidance sheet **2.3.4** and part 1 of the Good Practice Guide.

SUPERVISION

- Have a system to check that control measures are in place and that they are being followed. Refer to task guidance sheet **2.3.3**.
- Employers should make sure that employees have all the means to perform the checklist given below.

PERSONAL PROTECTIVE EQUIPMENT

- Refer to task guidance sheet **2.1.15** dedicated to Personal Protective Equipment.
- Risk assessment must be carried out to determine whether existing controls are adequate. If necessary, respiratory protective equipment (with the appropriate protection factor) should be provided and worn.
- Provide storage facilities to keep personal protective equipment clean when not in use.
- Replace respiratory protective equipment at intervals recommended by its suppliers.

EMPLOYEE CHECKLIST

- | | | | |
|--|---|---|---|
| <input type="checkbox"/> For wet dust suppression methods, make sure the water supply is working before starting the drilling equipment. | <input type="checkbox"/> Look for signs of damage, wear or poor operation of any equipment used. If you find any problems, tell your supervisor. | <input type="checkbox"/> respirable crystalline silica while the problem persists. | <input type="checkbox"/> Check and implement the measures of controlling the risk of bacterial growth within water sources used across site, focusing most on systems where water droplets will be generated. |
| <input type="checkbox"/> For dry dust collection methods, make sure the dust extraction system is switched on and is working. | <input type="checkbox"/> If you think there is a problem with your dust control equipment, ensure additional control measures are taken to reduce exposure to | <input type="checkbox"/> Clean up any control cabin using vacuum or wet cleaning methods. | |
| | | <input type="checkbox"/> Use, maintain and store any respiratory protective equipment provided in accordance with instructions. | |

This guidance sheet is aimed at employers to help them comply with the requirements of workplace health and safety legislation, by controlling exposure to respirable crystalline silica. Specifically, this sheet provides advice on dust control during the use of a drilling rig in hard rock quarries.

Following the key points of this task guidance sheet will help reduce exposure.

Depending on the specific circumstances of each case, it may not be necessary to apply all of the control measures identified in this sheet in order to minimise exposure

to respirable crystalline silica. i.e. to apply appropriate protection and prevention measures. This document should also be made available to persons who may be exposed to respirable crystalline silica in the workplace, in order that they may make the best use of the control measures which are implemented.

This sheet forms part of the Good Practices Guide on silica dust prevention, which is aimed specifically at the control of personal exposure to respirable crystalline silica in the workplace.

GOOD PRACTICES FOR WATER ASSISTED DUST SUPPRESSION

This activity relates to the use of water flooding and of atomised water mists to suppress the generation and lower the concentration of airborne crystalline silica dusts.

ACCESS

Restrict access to the work area to authorised personnel only.

DESIGN AND EQUIPMENT

- If possible, use water fed tools for cutting, grinding and shaping crystalline silica containing products.
- Consider the application of water sprays or trickles to working surfaces when water fed tools are not available.
- In circumstances where there will be no adverse impact on process conditions, product quality or health and safety, apply water mists in work areas where airborne crystalline silica may be generated by material and product handling.
- Ensure electrical systems have adequate protection when used with water flooding, spraying or misting.
- Take precautions to ensure the control of legionella and other biological agents in water storage and delivery systems.
- Take precautions to ensure that wastewater and sludges are disposed according to appropriate prescriptions.

MAINTENANCE

- Ensure water dust suppression equipment used in the task is maintained as advised by the supplier/installer in efficient working order and good repair.
- Replace consumables in accordance with the manufacturer's recommendations.



EXAMINATION AND TESTING

- Visually check all equipment for signs of damage at least once per week or, if it is in constant use, check it more frequently. If used infrequently, then check it before each use.
- Obtain information on the design performance of dust suppression equipment from the supplier. Keep this information to compare with future test results.
- Keep records of inspections for a suitable period of time which complies with national laws (minimum five years).
- Put in place measures to control the risk of bacterial growth within water sources used across site, focusing most on systems where water droplets will be generated.

CLEANING AND HOUSEKEEPING

- Clean water dust suppression equipment as instructed by the manufacturer/supplier.
- **Avoid accumulation of slurries/sludges.**
- Ensure spills are cleaned up immediately, and provide adequate spill control equipment.
- **DO NOT allow collected slurries/sludges to dry out and the dust to become airborne.**

TRAINING

- Give your employees information on the health effects associated with respirable crystalline silica dust.

- Provide employees with training on: dust exposure prevention; checking controls are working and using them; when and how to use any respiratory protective equipment provided and what to do if something goes wrong. Refer to task guidance sheet **2.3.4** and part 1 of the Good Practice Guide.

SUPERVISION

- Have a system to check that control measures are in place and that they are being followed. Refer to task guidance sheet **2.3.3**.
- Employers should make sure that employees have all the means to perform the checklist given below.

PERSONAL PROTECTIVE EQUIPMENT

- Refer to task guidance sheet **2.1.15** dedicated to Personal Protective Equipment.
- Risk assessment must be carried out to determine areas where personal protective equipment must be used. If necessary, respiratory protective equipment (with the appropriate protection factor) should be provided and worn.
- Provide storage facilities to keep personal protective equipment clean, when not in use.
- Replace personal protective equipment at intervals recommended by the manufacturer/supplier.

EMPLOYEE CHECKLIST

- | | | | |
|---|---|--|---|
| <input type="checkbox"/> Make sure that water dust suppression equipment is working properly. | <input type="checkbox"/> Protect water supplies against freezing. | <input type="checkbox"/> Clean up spills immediately. | <input type="checkbox"/> Check and implement the measures of controlling the risk of bacterial growth within water sources used across site, focusing most on systems where water droplets will be generated. |
| <input type="checkbox"/> Ensure water supplies are adequate with an uninterrupted supply during use for dust suppression. | <input type="checkbox"/> Look for signs of damage or malfunction, and if you find any tell your supervisor immediately. | <input type="checkbox"/> Clean dust suppression equipment regularly and after use. | |
| | | <input type="checkbox"/> Keep personal protective equipment clean and properly stored. | |

This guidance sheet is aimed at employers to help them comply with the requirements of workplace health and safety legislation, by controlling exposure to respirable crystalline silica. Specifically, this sheet provides good practice advice on dust control by using water flooding and atomised water mists.

Following the key points of this task guidance sheet will help reduce exposure.

Depending on the specific circumstances of each case, it may not be necessary to apply all of the control measures identified in this sheet in order to minimise exposure

to respirable crystalline silica. i.e. to apply appropriate protection and prevention measures. This document should also be made available to persons who may be exposed to respirable crystalline silica in the workplace, in order that they may make the best use of the control measures which are implemented.

This sheet forms part of the Good Practices Document on silica dust prevention, which is aimed specifically at the control of personal exposure to respirable crystalline silica dust in the workplace.

GOOD PRACTICES FOR QUARRY MOBILE EQUIPMENT – EXCAVATION AND HAULAGE

This sheet provides advice on the design and use of mobile equipment in a quarry. Following the key points of this task guidance sheet will prevent personal exposure to the dust released into the air of the cabin during quarry mobile equipment operations, including excavation and haulage. Among others, the equipment included in this task guidance sheet is: lorries, dumpers, wheel loaders, excavators or bulldozers.

ACCESS

Restrict access to the work area to authorised personnel only.

DESIGN AND EQUIPMENT

- Ensure the equipment/unit is fit for purpose and that it is well maintained.
- The cabin should be equipped with air conditioning system or fresh air supply.
- An air filter system (High Efficiency Particulate Arrestance – HEPA) should be installed which is designed to withstand a high loading of respirable dust particles.
- In order for the air conditioning system or fresh air supply to provide the greatest protection from dust exposure, the doors and windows of the cabin must be kept closed at all times while the machine is in operation. This will help to maintain the cabin under positive pressure.
- Where possible, the seat cover and other surfaces in the cabin should be designed such that they cannot retain dust and can easily be cleaned.
- Where possible, timing of extraction operations, to coincide with the wetter seasons of the year, will help to reduce airborne dust generation.
- In dry weather, use spray mist dust suppression in order to help reduce airborne dust generation. For example, rippers may be fitted with a mist boom mounted on the ripper/shank mechanism.

MAINTENANCE

- Maintain the air conditioning system as advised by the supplier, in effective and efficient working order.
- The air conditioning filter should be changed each time it is deemed necessary and at least at intervals advised by the manufacturer.



EXAMINATION AND TESTING

- Machine drivers must check that the air conditioning system is working within accepted parameters.
- A build up of fine dust on the internal surfaces of the driver's cabin might suggest a problem with the air conditioning system.
- Machine operators should check the condition of the filter (usually located behind the driver's seat or in the glove compartment) as recommended by the manufacturer.
- Any faults with the air conditioning/filtration system must be reported as soon as possible so that remedial action can be taken.
- Put in place measures to control the risk of bacterial growth within water sources used across site, focusing most on systems where water droplets will be generated.

CLEANING AND HOUSEKEEPING

- The driver should take precautions to avoid bringing in dust or mud.
- The cabin should be cleaned regularly (please refer to task guidance sheet **2.1.1**)
- Preference should be given to the use of vacuum or wet cleaning methods. Avoid using a dry brush when cleaning the internal surfaces of the driver's cabin.

TRAINING

- Give your employees information on the health effects associated with respirable crystalline silica dust.
- Provide employees with training on: dust exposure prevention; checking controls are working and using them; when and how to use any respiratory protective equipment provided and what to do if something goes wrong. Refer to task guidance sheet **2.3.4** (Training) and part 1 of the Good Practice Guide.

SUPERVISION

- Have a system to check that control measures are in place and that they are being followed. Refer to task guidance sheet **2.3.3** (Supervision).
- Employers should make sure that employees have all the means to perform the checklist given below.

PERSONAL PROTECTIVE EQUIPMENT

- Refer to task guidance sheet **2.1.15** dedicated to Personal Protective Equipment.
- Risk assessment must be carried out to determine whether existing controls are adequate. If necessary, respiratory protective equipment (with the appropriate protection factor) should be provided and worn.
- Provide storage facilities to keep personal protective equipment clean when not in use.
- Replace respiratory protective equipment at intervals recommended by its suppliers.

EMPLOYEE CHECKLIST

- | | | | |
|---|---|---|---|
| <input type="checkbox"/> Keep the cabin doors and windows closed at all times when the machine is in operation. | <input type="checkbox"/> Keep records of all safety checks on a daily check sheet. | <input type="checkbox"/> If you think there is a problem with your dust control equipment, ensure the additional measures are taken to reduce exposure to RCS while the problem persists. | <input type="checkbox"/> Use and maintain any respiratory protective equipment provided in accordance with instructions. |
| <input type="checkbox"/> Monitor the performance of the air conditioning system each time the machine is used. | <input type="checkbox"/> Look for signs of dust build up on the surfaces of the cabin. This may be a sign that the air filter is in poor condition. | <input type="checkbox"/> Keep interior of the cabin clean. | <input type="checkbox"/> Check and implement the measures of controlling the risk of bacterial growth within water sources used across site, focusing most on systems where water droplets will be generated. |
| <input type="checkbox"/> Check the condition of the air filter once a week. | | | |

This guidance sheet is aimed at employers to help them comply with the requirements of workplace health and safety legislation, by controlling exposure to respirable crystalline silica.

Following the key points of this task guidance sheet will help reduce exposure.

Depending on the specific circumstances of each case, it may not be necessary to apply all of the control measures identified in this sheet in order to minimise exposure

to respirable crystalline silica. i.e. to apply appropriate protection and prevention measures. This document should also be made available to persons who may be exposed to respirable crystalline silica in the workplace, in order that they may make the best use of the control measures which are implemented.

This sheet forms part of the Good Practices Guide on silica dust prevention, which is aimed specifically at the control of personal exposure to respirable crystalline silica in the workplace.

GOOD PRACTICES FOR QUARRY MOBILE PROCESSING PLANT

This sheet provides advice on the design and use of mobile processing plant in a quarry. Following the key points of this task guidance sheet will prevent personal exposure to the dust released into the air during quarry mobile plant processing, including rock crushing, screening, or the utilisation of conveyor belts.

ACCESS

Restrict access to the work area to authorised personnel only.

DESIGN AND EQUIPMENT

- If the mobile processing plant has a cabin, please refer to the task guidance sheet on 'Quarry mobile machine and equipment – excavation and haulage' (**2.2.43**).
- Please refer to the task guidance sheets **2.1.8**, **2.2.6**, **2.2.28**, which outline good practices for outdoor stockpiling, crushing and screening.
- Transfer points, screens and conveyors should be enclosed as far as possible and served with water suppression systems (check task guidance sheet **2.2.35**) and dust collectors (extraction systems).
- Where possible, timing of extraction and processing operations should coincide with the wetter seasons of the year, this will help to reduce airborne dust generation.
- Ensure that the equipment is designed and installed so as to be easily accessible for maintenance work.
- The control system of the mobile plant should allow to minimise presence of the workers in the exposed areas.
- Select appropriate mobile processing plants that are designed for optimal efficiency in the crushing operations in order to minimise dust generation.
- Where possible, the mobile processing plant should be placed in a position where dust generation is minimised.
- Where water-fed systems are used, take precautions to ensure the control of legionella and other biological agents in water storage and delivery systems.



MAINTENANCE

- Ensure equipment used in the task is maintained as advised by the supplier/installer in efficient working order and in good repair.
- Replace consumables (filters etc.) in accordance with the manufacturer's recommendations.

EXAMINATION AND TESTING

- Visually check the equipment at least once per week for signs of damage or, if it is in constant use, check it more frequently. If used infrequently, then check it before each use.
- Obtain information on the design performance of the dust suppression and/or extraction equipment from the supplier. Keep this information to compare with future test results.
- Keep records of inspections for a suitable period of time which complies with national laws (minimum five years).
- Check on a regular basis that extraction ducting and flexible hoses are not obstructed or damaged.

CLEANING AND HOUSEKEEPING

- Clean your workplace on a regular basis (check task guidance sheet **2.1.1**).
- Use vacuum or wet cleaning methods.
- **DO NOT clean up with a dry brush or using compressed air.**

TRAINING

- Give your employees information on the health effects associated with respirable crystalline silica dust.
- Provide employees with training on: dust exposure prevention; checking controls are working and using them; when and how to use any respiratory protective equipment provided and what to do if something goes wrong. Refer to task guidance sheet **2.3.4** (Training) and part 1 of the Good Practice Guide.

SUPERVISION

- Have a system to check that control measures are in place and that they are being followed. Refer to task guidance sheet **2.3.3** (Supervision).
- Employers should make sure that employees have all the means to perform the checklist given below.

PERSONAL PROTECTIVE EQUIPMENT

- Refer to task guidance sheet **2.1.15** dedicated to Personal Protective Equipment.
- Risk assessment must be carried out to determine whether existing controls are adequate. If necessary, respiratory protective equipment (with the appropriate protection factor) should be provided and worn.
- Provide storage facilities to keep personal protective equipment clean when not in use.
- Replace respiratory protective equipment at intervals recommended by its suppliers.

EMPLOYEE CHECKLIST

- | | | | |
|--|---|---|---|
| <input type="checkbox"/> Make sure the equipment is working properly. | <input type="checkbox"/> Look for signs of damage, wear or poor operation of any equipment used. If you find any problems, tell your supervisor. | <input type="checkbox"/> Use handling aids when available. | <input type="checkbox"/> Use, maintain and store any respiratory protective equipment provided in accordance with instructions. |
| <input type="checkbox"/> Make sure the dust extraction or water suppression systems is switched on and is working correctly. | <input type="checkbox"/> If you think there is a problem with your dust control equipment, ensure additional control measures are taken to reduce exposure to RCS while the problem persists. | <input type="checkbox"/> Clean up spills straight away. Use vacuum or wet cleaning methods. | |
| <input type="checkbox"/> Check that the flexible hoses are in good condition. | | <input type="checkbox"/> Clean up the cabin using vacuum cleaning methods. | |

This guidance sheet is aimed at employers to help them comply with the requirements of workplace health and safety legislation, by controlling exposure to respirable crystalline silica.

Following the key points of this task guidance sheet will help reduce exposure.

Depending on the specific circumstances of each case, it may not be necessary to apply all of the control measures identified in this sheet in order to minimise exposure

to respirable crystalline silica. i.e. to apply appropriate protection and prevention measures. This document should also be made available to persons who may be exposed to respirable crystalline silica in the workplace, in order that they may make the best use of the control measures which are implemented.

This sheet forms part of the Good Practices Guide on silica dust prevention, which is aimed specifically at the control of personal exposure to respirable crystalline silica in the workplace.